

PRODUCT MONOGRAPH

Pr **ULTIBRO[®] BREEZHALER[®]**

Indacaterol (as maleate)/glycopyrronium (as bromide) inhalation powder hard capsules

110 mcg/50 mcg per capsule

ULTIBRO[®] BREEZHALER[®] capsules to be used only with the supplied ULTIBRO[®]
BREEZHALER[®] inhalation device

Bronchodilator Combination for Oral Inhalation

Long-Acting Beta₂-Agonist (LABA) and Long-Acting Muscarinic Antagonist (LAMA)

Novartis Pharmaceuticals Canada Inc.
385 Bouchard Blvd.,
Dorval, Quebec
H9S 1A9

Date of Preparation:
December 19, 2013

Date of Revision:
January 12, 2018

ULTIBRO is a registered trademark.
BREEZHALER is a registered trademark.

Submission Control No: 210970

Table of Contents

PART I: HEALTH PROFESSIONAL INFORMATION.....3
SUMMARY PRODUCT INFORMATION3
INDICATIONS AND CLINICAL USE.....3
CONTRAINDICATIONS3
WARNINGS AND PRECAUTIONS.....4
ADVERSE REACTIONS.....9
DRUG INTERACTIONS12
DOSAGE AND ADMINISTRATION15
OVERDOSAGE17
ACTION AND CLINICAL PHARMACOLOGY18
STORAGE AND STABILITY.....22
SPECIAL HANDLING INSTRUCTIONS22
DOSAGE FORMS, COMPOSITION AND PACKAGING23

PART II: SCIENTIFIC INFORMATION24
PHARMACEUTICAL INFORMATION.....24
CLINICAL TRIALS25
DETAILED PHARMACOLOGY33
TOXICOLOGY33
REFERENCES36

PART III: CONSUMER INFORMATION.....37

Pr **ULTIBRO® BREEZHALER®**

Indacaterol (as maleate)/glycopyrronium (as bromide) inhalation powder hard capsules

PART I: HEALTH PROFESSIONAL INFORMATION

SUMMARY PRODUCT INFORMATION

Route of Administration	Dosage Form / Strength	Nonmedicinal Ingredients
Oral inhalation	Inhalation powder hard capsules, 110 mcg indacaterol as maleate and 50 mcg glycopyrronium as bromide	Carrageenan, FD&C Yellow5/Tartrazine, hypromellose, lactose monohydrate, magnesium stearate, potassium chloride, purified water

INDICATIONS AND CLINICAL USE

ULTIBRO BREEZHALER (indacaterol maleate and glycopyrronium bromide) is a combination of a long-acting beta₂-agonist (LABA) and a long-acting muscarinic antagonist (LAMA), indicated for the long-term once-daily maintenance bronchodilator treatment of airflow obstruction in patients with chronic obstructive pulmonary disease (COPD), including chronic bronchitis and emphysema, and for the reduction of exacerbations of COPD in patients with a history of exacerbations.

ULTIBRO BREEZHALER is not indicated for the treatment of acute episodes of bronchospasm.

ULTIBRO BREEZHALER is **not** indicated for asthma use. The safety and effectiveness of ULTIBRO BREEZHALER in asthma have not been established.

Geriatrics (> 65 years of age):

No dosage adjustment is required in patients over 65 years of age.

Pediatrics (< 18 years of age):

ULTIBRO BREEZHALER should not be used in patients under 18 years of age.

CONTRAINDICATIONS

ULTIBRO BREEZHALER (indacaterol maleate and glycopyrronium bromide) is contraindicated in:

- Patients with hypersensitivity to indacaterol maleate or glycopyrronium bromide, or to any other component of ULTIBRO BREEZHALER. For a complete listing, see the DOSAGE FORMS, COMPOSITION AND PACKAGING section of the product monograph.

- Patients with severe hypersensitivity to milk proteins.
- All LABA are contraindicated in patients with asthma without use of a long-term asthma control medication (see WARNINGS AND PRECAUTIONS). ULTIBRO BREEZHALER is not indicated for the treatment of asthma.

WARNINGS AND PRECAUTIONS

Serious Warnings and Precautions

WARNING: ASTHMA RELATED DEATH

Long-acting beta₂-adrenergic agonists (LABA) increase the risk of asthma-related death. Data from a large placebo controlled US study that compared the safety of another LABA (salmeterol) or placebo added to patients' usual asthma therapy showed an increase in asthma-related deaths in patients receiving salmeterol. This finding with salmeterol is considered a class effect of LABA, including indacaterol maleate, one of the active ingredients of ULTIBRO BREEZHALER.

ULTIBRO BREEZHALER is only indicated for COPD.

The safety and efficacy of ULTIBRO BREEZHALER in patients with asthma have not been established. ULTIBRO BREEZHALER is not indicated for the treatment of asthma.

General

Not for use in asthma

ULTIBRO BREEZHALER is only indicated for COPD. ULTIBRO BREEZHALER should not be used for the treatment of asthma due to the absence of data in this indication. ULTIBRO BREEZHALER is contraindicated in patients with asthma.

It has been shown that long-acting beta₂-adrenergic agonists may increase the risk of asthma-related death. Data from a 28-week, large placebo-controlled US study comparing the safety of a twice-daily long-acting beta₂-adrenergic agonist (salmeterol) with placebo, each added to usual asthma therapy, showed an increase in asthma-related deaths in patients receiving salmeterol (13 out of 13,176 in patients treated with salmeterol vs. 3 out of 13,179 in patients treated with placebo; RR 4.37, 95% CI 1.25, 15.34). The increased risk of asthma related death may represent a class effect of the long-acting beta₂-adrenergic agonists, including indacaterol maleate, one of the active ingredients of ULTIBRO BREEZHALER. No study adequate to determine whether the rate of asthma-related death is increased in patients treated with ULTIBRO BREEZHALER has been conducted.

Serious asthma-related events, including death, were reported in clinical studies with indacaterol maleate, one of the active ingredients of ULTIBRO BREEZHALER. The sizes of these studies

were not adequate to precisely quantify the differences in serious asthma exacerbation rates between treatment groups.

Data are not available to determine whether the rate of death in patients with COPD is increased by long-acting beta₂-adrenergic agonists such as indacaterol maleate, one of the active ingredients of ULTIBRO BREEZHALER.

Not for Acute Use

ULTIBRO BREEZHALER is not indicated for the treatment of acute episodes of bronchospasm, *i.e.* as rescue therapy. Acute symptoms should be treated with an inhaled short-acting beta₂-agonist. When prescribing ULTIBRO BREEZHALER, the healthcare professional should also provide the patient with an inhaled, short-acting bronchodilator for treatment of acute COPD symptoms.

When beginning treatment with ULTIBRO BREEZHALER, patients who have been taking inhaled, short-acting bronchodilators on a regular basis (e.g., four times a day) should be instructed to discontinue the regular use of these drugs and use them only for symptomatic relief of acute respiratory symptoms.

COPD Deterioration

ULTIBRO BREEZHALER should not be initiated in patients with acutely deteriorating COPD, which may be a life-threatening condition. The use of ULTIBRO BREEZHALER in this setting is inappropriate.

COPD may deteriorate acutely over a period of hours or chronically over several days or longer. If ULTIBRO BREEZHALER no longer controls the symptoms of bronchoconstriction, or the patient's inhaled, short-acting beta₂-agonist becomes less effective or the patient needs more inhalation of short-acting beta₂-agonist than usual, these may be markers of deterioration of disease. In this setting, a re-evaluation of the patient and the COPD treatment regimen should be undertaken at once. Increasing the daily dosage of ULTIBRO BREEZHALER beyond the recommended dose is not appropriate in this situation.

Excessive Use and Use with Other LABA and LAMA Products:

ULTIBRO BREEZHALER should not be used more often or at higher doses than recommended or in conjunction with products containing other long-acting beta-adrenergic agonists or long-acting muscarinic antagonists, drug classes to which the components of ULTIBRO BREEZHALER belong (see INTERACTIONS). Clinically significant cardiovascular effects and fatalities have been reported in association with excessive use of inhaled sympathomimetic drugs (see OVERDOSAGE).

Effects on ability to drive or use machines

No studies on the effects on the ability to drive and use machines have been performed. The occurrence of dizziness or blurred vision may influence the ability to drive and use machinery.

Anticholinergic effects

Like other anticholinergic containing–drugs, ULTIBRO BREEZHALER should be used with caution in patients with narrow-angle glaucoma or urinary retention.

Worsening of Narrow-Angle Glaucoma

ULTIBRO BREEZHALER should be used with caution in patients with narrow-angle glaucoma. Patients should be cautioned to avoid getting the drug powder into their eyes. They should be advised that this may result in precipitation or worsening of narrow-angle glaucoma. Prescribers and patients should be alert for signs and symptoms of acute narrow-angle glaucoma (e.g., eye pain or discomfort, blurred vision, visual halos or colored images in association with red eyes from conjunctival congestion and corneal edema). Instruct patients to consult a physician immediately should any of these signs or symptoms develop.

Worsening of Urinary Retention

ULTIBRO BREEZHALER should be used with caution in patients with urinary retention. Prescribers and patients should be alert for signs and symptoms of prostatic hyperplasia or bladder-neck obstruction (e.g., difficulty passing urine, painful urination). Instruct patients to consult a physician immediately should any of these signs or symptoms develop.

Cardiovascular

ULTIBRO BREEZHALER is a combination of a long-acting beta₂-agonist (indacaterol) and a long-acting muscarinic antagonist (glycopyrronium). Cardiovascular effects, such as cardiac arrhythmias, e.g., atrial fibrillation and tachycardia, may be seen after the administration of sympathomimetic agents and muscarinic receptor antagonists, including ULTIBRO BREEZHALER. In case such effects occur, treatment may need to be discontinued.

Cardiovascular effects such as tachycardia, arrhythmia, palpitations, myocardial ischaemia, angina pectoris, hypertension or hypotension have been associated with use of with beta-adrenergic agonists. In addition, beta-adrenergic agonists have been reported to produce electrocardiogram (ECG) changes, such as flattening of the T wave, prolongation of the QTc interval, and ST segment depression. Therefore, ULTIBRO BREEZHALER like all products containing beta-adrenergic agonists, should be used with caution in patients with cardiovascular disorders, especially coronary insufficiency, acute myocardial infarction, cardiac arrhythmias, and hypertension.

Heart Rate

Like other beta₂-agonists, indacaterol can produce clinically significant cardiovascular effects in some patients as measured by an increase in pulse rate, systolic or diastolic blood pressure or cardiac arrhythmias such as supraventricular tachycardia and extrasystoles. If such effects occur, ULTIBRO BREEZHALER may need to be discontinued.

QT Interval

Like other beta₂-agonists, caution is recommended if ULTIBRO BREEZHALER is administered to patients with a known history of QTc prolongation, risk factors for torsade de pointes (e.g.,

hypokalemia), or patients who are taking medications known to prolong the QTc interval (see DRUG INTERACTIONS, Drugs known to prolong the QTc interval).

Endocrine and Metabolism

Coexisting Conditions

ULTIBRO BREEZHALER should be used with caution in patients with convulsive disorders or thyrotoxicosis, and in patients who are unusually responsive to sympathomimetic amines as it contains a sympathomimetic amine, indacaterol maleate. Doses of the related beta₂-agonist salbutamol, when administered intravenously, have been reported to aggravate pre-existing diabetes mellitus and ketoacidosis.

Hypokalemia

Beta₂-agonists medications may produce significant hypokalemia in some patients which has the potential to produce adverse cardiovascular effects (see ACTION AND CLINICAL PHARMACOLOGY). The decrease in serum potassium is usually transient, not requiring supplementation. In patients with severe COPD, hypokalemia may be potentiated by hypoxia and concomitant treatment (see DRUG INTERACTIONS), which may increase the susceptibility to cardiac arrhythmias. Therefore, ULTIBRO BREEZHALER should be used with caution in patients predisposed to low levels of serum potassium.

Hyperglycemia

Inhalation of high doses of beta₂-adrenergic agonists may produce increases in plasma glucose. Upon initiation of treatment with ULTIBRO BREEZHALER plasma glucose should be monitored more closely in diabetic patients. ULTIBRO BREEZHALER has not been investigated in patients for whom diabetes mellitus is not well controlled.

Immune

Hypersensitivity

Immediate hypersensitivity reactions may occur after administration of ULTIBRO BREEZHALER. If signs suggesting allergic reactions occur in particular, angioedema (including difficulties in breathing or swallowing, swelling of tongue, lips and face), urticaria or skin rash, ULTIBRO BREEZHALER should be discontinued immediately and alternative therapy instituted. The patient should NOT be re-challenged with ULTIBRO BREEZHALER (see CONTRAINDICATIONS).

Ophthalmologic

Worsening of Narrow-Angle Glaucoma (see Anticholinergic Effects).

Renal

Patients with severe renal impairment

For patients with severe renal impairment (estimated glomerular filtration rate below

30 mL/min/1.73 m²) including those with end-stage renal disease requiring dialysis, ULTIBRO BREEZHALER should be used only if the expected benefit outweighs the potential risk (see ACTION AND CLINICAL PHARMACOLOGY). These patients should be monitored closely for potential adverse drug reactions.

Worsening of Urinary Retention (see Anticholinergic Effects)

Respiratory

Paradoxical bronchospasm

As with other inhalation therapy, administration of ULTIBRO BREEZHALER may result in paradoxical bronchospasm that may be life-threatening. If paradoxical bronchospasm occurs, ULTIBRO BREEZHALER should be discontinued immediately and alternative therapy instituted.

Special Populations

Pregnant Women: There are no data from the use of ULTIBRO BREEZHALER in pregnant women. Likewise there are no data from the use of either indacaterol or glycopyrronium in pregnant women. Reproductive toxicity was seen for indacaterol as an increased incidence of one skeletal variation following administration to rabbits (See TOXICOLOGY).

The potential risk for humans is unknown. Therefore as there is no adequate experience in pregnant women, ULTIBRO BREEZHALER should only be used during pregnancy if the expected benefit to the patient justifies the potential risk to the fetus. Women should be advised to contact their physician if they become pregnant while taking ULTIBRO BREEZHALER.

Labour and delivery: There are no adequate and well-controlled human studies that have investigated the effects of indacaterol and glycopyrronium, alone or in combination, during labour and delivery. Because beta-agonists may potentially interfere with uterine contractility, ULTIBRO BREEZHALER should be used during labour only if the potential benefit justifies the potential risk.

Nursing Women: It is not known whether indacaterol and/or glycopyrronium pass into human breast milk. Indacaterol and glycopyrronium (including their metabolites) have been detected in the milk of lactating rats (see TOXICOLOGY). Therefore the use of ULTIBRO BREEZHALER by breastfeeding women should only be considered if the expected benefit to the woman is greater than any possible risk to the infant.

Pediatrics (< 18 years of age): ULTIBRO BREEZHALER is not indicated for use in children and therefore should not be used in patients under 18 years of age.

Hepatic Impairment: ULTIBRO BREEZHALER can be used at the recommended dose in patients with mild and moderate hepatic impairment. There are no data available for the use of ULTIBRO BREEZHALER in patients with severe hepatic impairment, therefore caution should be observed in these patients.

Renal Impairment: For patients with severe renal impairment (estimated glomerular filtration

rate below 30 mL/min/1.73 m²) including those with end-stage renal disease requiring dialysis, ULTIBRO BREEZHALER should be used only if the expected benefit outweighs the potential risk (see ACTION AND CLINICAL PHARMACOLOGY). These patients should be monitored closely for potential adverse drug reactions.

Monitoring and Laboratory Tests

Potentially serious hypokalemia has been observed with other beta-agonist therapies, which may increase susceptibility to cardiac arrhythmias. It is therefore recommended that serum potassium levels be monitored in patients predisposed to low levels of serum potassium. No clinically relevant hypokalemic effect was observed following ULTIBRO BREEZHALER at recommended doses.

Due to the hyperglycemic effect observed with other beta-agonists, additional blood glucose monitoring is recommended in diabetic patients.

ADVERSE REACTIONS

Adverse Drug Reaction Overview

Long-acting beta₂-adrenergic agonists such as indacaterol, one of the active ingredients of ULTIBRO BREEZHALER increase the risk of asthma-related death. ULTIBRO BREEZHALER is not indicated for the treatment of asthma (See BOXED WARNING, INDICATION, CONTRAINDICATION, and WARNING AND PRECAUTIONS).

ULTIBRO BREEZHALER is a combination of a long-acting beta₂-agonist (LABA) and a long-acting muscarinic antagonist (LAMA). Adverse reactions to ULTIBRO BREEZHALER are expected to be similar in nature to other beta₂-agonists and muscarinic antagonists. Adverse reactions that have been associated with muscarinic antagonists include cardiovascular effects (atrial arrhythmias and tachycardia), ocular disorders (e.g., blurred vision), urinary retention, gastrointestinal disorders, dry mouth and cough. Adverse reactions that have been associated with beta₂-agonists include immediate hypersensitivity reactions (urticaria, rash, bronchospasm, edema and angioedema), cardiovascular effects (tachycardia, arrhythmia, palpitations, myocardial ischaemia, hypertension or hypotension), hypokalemia, hyperglycemia, headache, nervousness, insomnia, muscle spasms, fatigue, malaise, and tremor.

The most common adverse drug reactions related to the drug product (≥3% and greater than placebo) were headache, cough, and oropharyngeal pain (including throat irritation).

Clinical Trial Adverse Drug Reactions

Because clinical trials are conducted under very specific conditions the adverse reaction rates observed in the clinical trials may not reflect the rates observed in practice and should not be compared to the rates in the clinical trials of another drug. Adverse drug reaction information from clinical trials is useful for identifying drug-related adverse events and for approximating rates.

The safety profile of ULTIBRO BREEZHALER is based on 1882 patients with a clinical diagnosis of moderate to very severe COPD who have received at least one dose of ULTIBRO BREEZHALER 110/50 mcg once-daily. This includes 1710 patients exposed to ULTIBRO BREEZHALER for 12 weeks (3 months) or longer (up to 15 months). Patients with clinically significant cardiovascular abnormalities and significant ECG findings at baseline were excluded from these studies.

The presentation of the safety profile of ULTIBRO BREEZHALER takes into account on the experience with ULTIBRO BREEZHALER in its pivotal clinical trial program as well as the clinical and post-marketing experience with the individual monotherapy components.

6-Month Safety Data:

To evaluate the safety of ULTIBRO BREEZHALER compared to placebo the first 6-month data for Study A2307 was pooled with the data from Study A2303 as these 2 studies had similar designs and patient populations. The adverse drug reactions from the 6-month safety data presented below are listed by MedDRA system organ class.

Table 1 Number and frequency of Adverse drug reactions ($\geq 1.0\%$ and higher than placebo) observed with ULTIBRO BREEZHALER in two placebo-controlled clinical trials

Adverse drug reactions	Indacaterol/ glycopyrronium 110/50 mcg once daily N=699 n (%)	Placebo N=345 n (%)
Infections and infestations		
Urinary tract infection	13 (1.9)	3 (0.9)
Sinusitis	11 (1.6)	2 (0.6)
Rhinitis	8 (1.1)	3 (0.9)
Nervous system disorders		
Dizziness	12 (1.7)	3 (0.9)
Headache	21 (3.0)	5 (1.4)
Respiratory, thoracic and mediastinal disorders		
Cough	40 (5.7)	11 (3.2)
Oropharyngeal pain including throat irritation	23 (3.3)	9 (2.6)
Gastrointestinal disorders		
Dyspepsia	15 (2.1)	4 (1.2)
Dental caries	8 (1.1)	2 (0.6)
Musculoskeletal and connective tissue disorders		
Musculoskeletal pain	7 (1.0)	1 (0.3)
General disorders and administration site conditions		
Pyrexia [^]	15 (2.1)	5 (1.4)
Chest pain	11 (1.6)	2 (0.6)
[^] new adverse drug reaction observed with the combination ULTIBRO BREEZHALER but not with the monotherapy components.		

Less Common Clinical Trial Adverse Drug Reactions (<1%)

Cardiac disorders: ischaemic heart disease, atrial fibrillation

Eye disorders: glaucoma*

Gastrointestinal disorders: dry mouth

General disorders: fatigue

Immune system disorders: hypersensitivity

Musculoskeletal and connective tissue disorders: muscle spasm, myalgia

Nervous system disorders: paresthesia

Psychiatric disorders: insomnia

Renal and urinary disorders: bladder obstruction and urinary retention

Respiratory, thoracic and mediastinal disorders: epistaxis

Skin and subcutaneous tissue disorders: pruritus/rash

*adverse drug reaction observed with the combination ULTIBRO BREEZHALER but not with the monotherapy components.

12-Month Trials

For the 12-month trial A2307 comparing ULTIBRO BREEZHALER (n=226) and placebo (n=113), there were no notable differences in demographics across treatment groups. The mean age for the total population was 62.6 years. Women comprised 23.1% of the total population. Caucasian and Asian patients represented 80.5% and 19.5% of patients, respectively. The proportion of patients in each age group (< 65 years, 65 years to < 75 years, and ≥ 75 years) was similar across treatment groups. The overall percentage of patients with adverse events was similar (57.8% and 56.6%, respectively). Overall, the most commonly reported adverse event was COPD (including disease progression and exacerbations; ULTIBRO BREEZHALER 28.0% vs. placebo 25.7%). Viral upper respiratory tract infection, upper respiratory tract infection, and hypertension adverse events were reported for a lower percentage of patients in the ULTIBRO BREEZHALER group than the placebo group. Cough, lower respiratory tract infections and pyrexia were reported for a slightly higher percentage of patients in the ULTIBRO BREEZHALER group compared with placebo. The percentage of patients with pneumonia was 3.6% in the ULTIBRO BREEZHALER and 0 in the placebo group.

For the 12-month trial A2318 comparing ULTIBRO BREEZHALER (n=1680) and fluticasone/salmeterol 500/50 mcg (n=1682) in moderate to very severe patients, there were no notable differences in demographics across treatment groups. The mean age for the total population was 64.6 years. Women comprised 23.9% of the total population. Caucasian and Asian patients represented 77.7% and 18.4% of patients, respectively. The proportion of patients in each age group (< 65 years, 65 years to < 75 years, and ≥ 75 years) was similar across treatment groups. The overall percentage of patients with adverse events was similar (86.9% and 89.2%, respectively). Overall, the most commonly reported adverse event was COPD worsening; ULTIBRO BREEZHALER 77.4% vs. fluticasone/salmeterol 81.8%). Other frequently reported adverse events (e.g., >5% in both treatment arms) were nasopharyngitis, viral upper respiratory tract infection and upper respiratory tract infection bacterial. Overall, there were no meaningful differences in adverse event frequencies between the treatment arms.

64-Week Trial

In a 64-week trial A2304 comparing ULTIBRO BREEZHALER (n=729), glycopyrronium (n=740) and open-label tiotropium (n=737) in severe to very severe patients, the most frequently reported adverse event was COPD (including disease progression and exacerbations), which was reported with a similar frequency across all treatment groups (87 - 88%). Other frequently reported adverse events (>10% in the ULTIBRO BREEZHALER group) were bacterial upper respiratory tract infection, nasopharyngitis and viral upper respiratory tract infection. There was no evidence of a higher risk for any adverse event in severe to very severe COPD patients.

ULTIBRO BREEZHALER showed similar adverse drug reactions as the individual monotherapy components. As ULTIBRO BREEZHALER contains indacaterol and glycopyrronium, the type and severity of adverse reactions associated with each of the monotherapy components may be expected in the combination.

Special populations

In elderly patients above 75 years of age the frequencies of urinary tract infection were higher on ULTIBRO BREEZHALER than on placebo, with 3.5 versus 2.8%, respectively.

Additional Adverse Reactions from clinical trials: The following adverse reactions not previously listed in COPD patients treated with ULTIBRO BREEZHALER have been identified from a database of 10000 patients with a clinical diagnosis of moderate to very severe COPD who have received at least one dose of ULTIBRO BREEZHALER 110/50 mcg once-daily. This includes 4352 patients exposed to ULTIBRO BREEZHALER for 4 weeks (1 month) up to 15 months: gastroenteritis, hyperglycemia and diabetes mellitus, nasopharyngitis, palpitations, paradoxical bronchospasm, peripheral oedema, pain in extremity, tachycardia, upper respiratory tract infection.

Post-Market Adverse Drug Reactions

The following adverse drug reaction has been reported in post-marketing experience. Because these reactions are reported voluntarily from a population of uncertain size, it is not always possible to reliably estimate their frequency or establish a causal relationship to drug exposure. Adverse drug reactions are listed according to system organ classes in MedDRA.

Immune system disorders: Angioedema

Respiratory, thoracic and mediastinal disorders: Dysphonia

Post-market adverse reactions such as hypersensitivity reactions, paradoxical bronchospasm, tachycardia/heart rate increase/palpitations, pruritus/rash and dizziness have been identified for indacaterol 150 mcg and 300 mcg once-daily. Hypersensitivity reactions, paradoxical bronchospasm, and pruritus have also been identified for glycopyrronium 50 mcg once-daily.

DRUG INTERACTIONS

Overview

No specific drug-drug interaction studies were conducted with ULTIBRO BREEZHALER. Information on ULTIBRO BREEZHALER is based on the potential for interactions for each of its two monotherapy components.

Potential interactions with Indacaterol

Beta-adrenergic blockers

Beta-adrenergic blockers may weaken or antagonize the effect of beta₂-adrenergic agonists. Therefore ULTIBRO BREEZHALER should not be given together with beta-adrenergic blockers (including eye drops) unless there are compelling reasons for their use. Where required, cardioselective beta-adrenergic blockers could be considered, although they should be administered with caution.

Drugs known to prolong QTc interval

ULTIBRO BREEZHALER, as other beta₂-adrenergic agonist containing drugs, should be administered with caution to patients treated with monoamine oxidase inhibitors, tricyclic antidepressants, or drugs known to prolong the QT interval, as any effect of these on the QT interval may be potentiated. Drugs known to prolong the QT-interval may increase the risk of ventricular arrhythmia (see WARNINGS AND PRECAUTIONS).

Sympathomimetic agents

Concomitant administration of other sympathomimetic agents, such as short-acting or long-acting beta agonists (alone or as part of combination therapy) may potentiate the undesirable effects of ULTIBRO BREEZHALER (see WARNINGS AND PRECAUTIONS).

Treatments Leading to Hypokalemia

Beta-agonists have been associated with reductions in serum potassium levels. Concomitant treatment with xanthine derivatives, oral corticosteroids (e.g. prednisone), or non-potassium sparing diuretics may potentiate any hypokalemic effect of adrenergic agonists (see WARNINGS AND PRECAUTIONS).

Metabolic and transporter based drug interaction

Co-administration of the CYP3A4 inhibitor erythromycin with indacaterol resulted in an increase of 1.4- to 1.6-fold for AUC and 1.2 fold for C_{max} of indacaterol. Co-administration with the prototypic inhibitor of P-glycoprotein (P-gp), verapamil, resulted in 1.4- to two-fold increase in AUC and 1.5-fold increase in C_{max} of indacaterol. Combined inhibition of P-gp and CYP3A4 by the very strong dual inhibitor ketoconazole caused a 2-fold and 1.4-fold increase in AUC and C_{max} of indacaterol, respectively. Concomitant treatment with ritonavir, another dual inhibitor of CYP3A4 and P-gp, resulted in a 1.6- to 1.8-fold increase in AUC whereas C_{max} was unaffected.

Potential Interactions with Glycopyrronium

Anticholinergics

There is a potential for an interaction with concomitantly used anticholinergic medications that leads to an additive pharmacological effect. Therefore, avoid co-administration of ULTIBRO BREEZHALER with other anticholinergic-containing drugs as this may lead to an increase in undesirable anticholinergic effects.

Cimetidine or other inhibitors of organic cation transport

In a clinical study in healthy volunteers, cimetidine, an inhibitor of organic cation transport which is thought to contribute to the renal excretion of glycopyrronium, increased total exposure (AUC) to glycopyrronium by 22% and decreased renal clearance by 23%. Based on the magnitude of these changes, no clinically relevant drug interaction is expected when glycopyrronium is co-administered with cimetidine or other inhibitors of the organic cation transport.

Drug-Drug Interactions

In clinical studies ULTIBRO BREEZHALER has been used concomitantly with other drugs commonly used to treat COPD including sympathomimetic bronchodilators, oral and inhaled corticosteroids. No safety findings were observed to contraindicate administration of these agents with ULTIBRO BREEZHALER.

Table 2 Established or Potential Drug-Drug Interactions

Drug	Ref.	Effect	Clinical Comment
<i>Potential Interactions with Indacaterol</i>			
Beta-adrenergic blockers (including ophthalmic agents)	T	Potential pharmacodynamic interaction (antagonism of pulmonary effects resulting in severe bronchospasm)	If concomitant therapy is required, consider cautious use of cardioselective β -adrenergic blocking agents
Xanthine derivatives	T	Potential pharmacodynamic interaction (increased risk of hypokalemia)	Cautious use is recommended
Corticosteroids	T	Potential pharmacodynamic interaction (increased risk of hypokalemia)	Cautious use is recommended
Diuretics, non-potassium sparing (i.e. loop or thiazide diuretics)	T	Potential pharmacodynamic interaction (increased risk of hypokalemia)	Cautious use is recommended
MAO inhibitors	T	Potential pharmacodynamic interaction (prolongation of the QT _c interval and increased risk of ventricular arrhythmias)	Caution is recommended during concomitant therapy
Tricyclic antidepressants	T	Potential pharmacodynamic interaction (prolongation of the QT _c interval and increased risk of ventricular arrhythmias)	Caution is recommended during concomitant therapy
QTc prolonging drugs	T	Potential pharmacodynamic interaction (prolongation of the QT _c interval and increased risk of ventricular arrhythmias)	Caution is recommended during concomitant therapy
Anticholinergics	T	Potential pharmacodynamic interaction (additive pharmacologic and adverse	Caution recommended for concomitant use of glycopyrronium and

		effects)	anticholinergic agents administered by any route
Sympathomimetic agents	T	Potential pharmacodynamic interaction (additive pharmacologic and adverse effects)	Caution recommended for concomitant use of indacaterol and sympathomimetic agents administered by any route
Inhibitors of CYP3A4 and P-gp efflux transporter	CT	Potential pharmacokinetic interaction with CYP3A4 inhibitors	Caution should be exercised when considering co-administration with long-term ketoconazole and other known strong CYP3A4 inhibitors (e.g., ritonavir, indinavir, itraconazole, lopinavir, nelfinavir, saquinavir, voriconazole)
<i>Potential Interactions with Glycopyrronium</i>			
Cimetidine	CT	Increased total exposure (AUC) to glycopyrronium by 22% and decreased renal clearance by 23%.	No clinically relevant drug interaction is expected in patients with normal renal function and also in patients with mild to moderate renal impairment.
Legend: C = Case Study; CT = Clinical Trial; CS = Class Statements; T = Theoretical			

Drug-Food Interactions

Interactions with food have not been established. No clinically relevant effect of food would be expected and therefore a food interaction study was not conducted.

Drug-Herb Interactions

Interactions with herbal products have not been established.

Drug-Laboratory Test Interactions

Interactions with laboratory tests have not been established.

DOSAGE AND ADMINISTRATION

Dosing Considerations

- Counseling by doctors on smoking cessation should be the first step in treating patients with COPD who smoke, independent of the clinical presentation i.e. chronic bronchitis (with or without airflow limitation) or emphysema. Cessation of smoking produces dramatic symptomatic benefits and has been shown to confer a survival advantage.
- As with other inhaled drugs containing beta₂-adrenergic agents, ULTIBRO BREEZHALER should not be used more often than recommended, at higher doses than recommended, or in conjunction with other medicines containing LABA and/or LAMA, as an overdose may result.

- When beginning treatment with ULTIBRO BREEZHALER patients who have been taking rapid onset, short duration, inhaled beta₂-agonists on a regular basis (e.g., q.i.d) should be instructed to discontinue the regular use of these drugs and use them only for symptomatic relief if they develop acute symptoms of asthma while taking ULTIBRO BREEZHALER.
- Patients should be made aware that for optimum benefit, ULTIBRO BREEZHALER must be used regularly, even when asymptomatic.

Recommended Dose and Dosage Adjustment

The recommended dosage of ULTIBRO BREEZHALER is the once-daily oral inhalation of the content of one 110/50 mcg capsule using the ULTIBRO BREEZHALER inhaler.

Dosing in special populations

Renal impairment

ULTIBRO BREEZHALER can be used at the recommended dose in patients with mild to moderate renal impairment. In patients with severe renal impairment or end-stage renal disease requiring dialysis ULTIBRO BREEZHALER should be used only if the expected benefit outweighs the potential risk (See also WARNINGS AND PRECAUTIONS and CLINICAL PHARMACOLOGY).

Hepatic impairment

ULTIBRO BREEZHALER can be used at the recommended dose in patients with mild and moderate hepatic impairment. No data are available for subjects with severe hepatic impairment. (See also CLINICAL PHARMACOLOGY).

Elderly patients

ULTIBRO BREEZHALER can be used at the recommended dose in elderly patients 65 years of age and older.

Pediatrics

ULTIBRO BREEZHALER should not be used in patients under 18 years of age.

Administration

ULTIBRO BREEZHALER is recommended for once-daily administration at the same time each day.

ULTIBRO BREEZHALER capsules must be administered only by the oral inhalation route and only using the ULTIBRO BREEZHALER inhaler.

ULTIBRO BREEZHALER capsules must not be swallowed (see also OVERDOSAGE).

ULTIBRO BREEZHALER capsules must always be stored in the blister to protect from moisture, and only removed IMMEDIATELY BEFORE USE (see also PHARMACEUTICAL INFORMATION).

When prescribing ULTIBRO BREEZHALER, patients should be instructed on the correct use of the inhaler.

Patients who do not experience improvement in breathing should be asked if they are swallowing the medicine rather than inhaling it.

Missed Dose

If a dose is missed, it should be taken as soon as possible. Patients should be instructed not to take more than one dose in a day.

OVERDOSAGE

In a single dose study in healthy volunteers the 4-fold of the therapeutic dose of ULTIBRO BREEZHALER (four dose steps of 110/50 mcg separated by one hour, each) was well tolerated with no relevant effects on heart rate, QTc-interval, serum potassium or blood glucose.

In COPD patients, doses of up to 600/100 mcg indacaterol/glycopyrronium were inhaled over two weeks and there were no relevant effects on heart rate, QTc-interval, blood glucose or serum potassium. There was an increase in ventricular ectopies after 14 days of dosing with 300/100 and 600/100 mcg indacaterol/glycopyrronium. In four patients, non-sustained ventricular tachycardia was recorded with the longest episode recorded being 9 beats (4 seconds).

ULTIBRO BREEZHALER contains both indacaterol and glycopyrronium; therefore, the risks associated with overdosage for the individual monotherapy components described below apply to ULTIBRO BREEZHALER. If overdose occurs, discontinue ULTIBRO BREEZHALER and initiate appropriate symptomatic and/or supportive therapy. In serious cases, patients should be hospitalised. The judicious use of a cardioselective beta-receptor blocker may be considered, bearing in mind that such medicine can produce bronchospasm. Cardiac monitoring (including electrocardiography) is recommended in cases of overdosage.

There is insufficient evidence to determine if dialysis is beneficial for overdosage of ULTIBRO BREEZHALER.

Indacaterol

The expected signs and symptoms of overdosage with indacaterol are those of excessive beta-adrenergic stimulation, *i.e.*, angina, hypertension or hypotension, tachycardia with rates up to 200 bpm, tremor, palpitations, nervousness, headache, nausea, dry mouth, vomiting, drowsiness, muscle cramps, ventricular arrhythmias, metabolic acidosis, fatigue, malaise, insomnia, hypokalaemia and hyperglycaemia. As with all inhaled sympathomimetic medications, cardiac arrest and even death may be associated with an overdose of ULTIBRO BREEZHALER.

Glycopyrronium

The expected signs and symptoms of overdose with glycopyrronium are those of exaggerated anticholinergic effects, i.e. increased intraocular pressure causing pain, vision disturbances or reddening of the eye, obstipation or voiding difficulties. However, orally inhaled glycopyrronium at doses of 100 mcg and 200 mcg once-daily for 28 days were well tolerated.

For management of a suspected drug overdose, contact your regional Poison Control Centre.

ACTION AND CLINICAL PHARMACOLOGY

Mechanism of Action

ULTIBRO BREEZHALER is a once-daily fixed-dose combination of two bronchodilators, indacaterol, a long-acting beta₂-adrenergic agonist (LABA) and glycopyrronium, a long-acting muscarinic receptor antagonist (LAMA). When indacaterol and glycopyrronium are administered together in ULTIBRO BREEZHALER, they provide additive efficacy due to their different mode of action targeting different receptors and pathways to achieve bronchial smooth muscle relaxation.

Indacaterol is a selective beta₂-adrenergic agonist. Its pharmacological effects are at least in part attributable to stimulation of intracellular adenylyl cyclase, the enzyme that catalyzes the conversion of adenosine triphosphate (ATP) to cyclic-3', 5'-adenosine monophosphate (cAMP). In the lung, increased cAMP levels cause relaxation of bronchial smooth muscle, resulting in bronchodilation.

Although beta₂-receptors are the predominant adrenergic receptors in bronchial smooth muscle and beta₁-receptors are the predominant receptors in the human heart, there are also beta₂-adrenergic receptors in the human heart comprising 10% to 50% of the total adrenergic receptors. The precise function of beta₂-adrenergic receptors in the heart is unclear, but their presence raises the possibility that even highly selective beta₂-adrenergic agonists may have cardiac effects.

Glycopyrronium is an inhaled long-acting muscarinic receptor antagonist (anticholinergic) for once-daily maintenance bronchodilator treatment of COPD. Parasympathetic nerves are the major bronchoconstrictive neural pathway in airways, and cholinergic tone is the key reversible component of airflow obstruction in COPD. Glycopyrronium works by blocking the bronchoconstrictor action of acetylcholine on airway smooth muscle cells, thereby dilating the airways.

Pharmacodynamics

Primary pharmacodynamic effects

The combination of indacaterol and glycopyrronium in ULTIBRO BREEZHALER showed a rapid onset of bronchodilation within 5 minutes after dosing. The effect remained constant over the whole 24 h dosing interval.

The mean bronchodilator effect derived from serial FEV₁ measurements over 24 h was greater by 0.32 L compared to placebo after 26 weeks of treatment. The effect was also greater compared to indacaterol or glycopyrronium alone (difference 0.11 L, for each comparison).

Secondary pharmacodynamic effects

The characteristic adverse effects of inhaled beta₂-adrenergic agonists and inhaled muscarinic receptor antagonists are the result of activation of systemic beta₂-adrenergic receptors and blockade of muscarinic receptors after systemic absorption of the drugs.

Effects on heart rate

Heart rate effects in healthy volunteers were investigated after a single dose of indacaterol/glycopyrronium 440/200 mcg administered in four dose steps separated by one hour and compared to the effects of placebo, 600 mcg indacaterol and 200 mcg glycopyrronium.

The largest time matched heart rate increase for indacaterol/glycopyrronium compared to placebo was +5.69 bpm, the largest decrease was -2.51 bpm.

QT-interval

A thorough QT (TQT) -study in healthy volunteers with doses of inhaled indacaterol up to 600 mcg did not demonstrate a clinically relevant effect on the QT-interval. No QT-prolongation was observed in a TQT study after inhalation of 400 mcg glycopyrronium.

The effects of ULTIBRO BREEZHALER on QTc-interval were investigated in healthy volunteers after inhalation of indacaterol/glycopyrronium 440/200 mcg in four dose steps separated by one hour. No clinically relevant prolongation of the QT interval was observed.

In COPD patients, doses up to 600/100 mcg indacaterol/glycopyrronium showed a higher proportion of patients with QTcF increases vs. baseline between 30 ms and 60 ms (ranging from 16.0% to 21.6% vs. 1.9% for placebo), but there were no QTcF increases >60 ms from baseline. The highest dose level of 600/100 indacaterol/glycopyrronium also showed a higher proportion of absolute QTcF values >450 ms (12.2% vs. 5.7% for placebo).

Serum potassium and blood glucose

In healthy volunteers, after administration of indacaterol/glycopyrronium 440/200 mcg, the effects on serum potassium and blood glucose were very small.

Tachyphylaxis

There was no evidence for tachyphylaxis to the effect of ULTIBRO BREEZHALER over time when compared to placebo or its monotherapy components.

Pharmacokinetics

Table 3 Summary of Pharmacokinetic Parameters

	C_{max} [pg/mL]	T_{1/2} [h]	AUC_{0-24h} [pg*h/mL]	Clearance (CL) [L/h]	Volume of distribution (V_z) [L]
Indacaterol					
	100 (39) ^{a)}	45.5-126 ^{b)}	1150 (551) ^{a)}	18.8 -23.3 ^{c)}	2360-2560 ^{c)}
Glycopyrronium					
Single dose	146 (109) ^{g)}	52.5 (12.7) ^{d)}	n.d.	23.1 (7.46) ^{d)}	82.7 (21.7) ^{d) f)}
Multiple dose (steady state)	166 (97.3) ^{g)}	13.4 (8.02) ^{e)} 20.8 (8.61) ^{e)} 21.6 (3.24) ^{e)}	464 (213) ^{g)}	17.6 (6.4) ^{g)}	n.d.
Notes: n.d.= not determined; ^{a)} Arithmetic mean (SD) systemic exposure in COPD patients treated once daily for 14/15 days with 75 mcg indacaterol; ^{b)} Range of arithmetic mean elimination half-lives observed across clinical trials; ^{c)} Determined following intra-venous indacaterol administration; ^{d)} Determined in a biopharmaceutical study in healthy volunteers; ^{e)} Determined in a pharmacokinetic study in COPD patients for doses of 50, 100 and 200 mcg respectively ^{f)} Steady-state volume of distribution (V _{ss}), determined in a biopharmaceutical study in healthy volunteers ^{g)} Determined in COPD patients for a dose of 50 mcg					

ULTIBRO BREEZHALER

Following inhalation of ULTIBRO BREEZHALER, the median time to reach peak plasma concentrations was similar to monotherapy^{1,2}, i.e., approximately 15 minutes for indacaterol and 5 minutes for glycopyrronium.

Based on the *in vitro* performance data, the dose of indacaterol delivered to the lung is expected to be similar for ULTIBRO BREEZHALER 110/50 mcg and indacaterol 150 mcg monotherapy product. The steady-state exposure to indacaterol after ULTIBRO BREEZHALER 110/50 mcg inhalation was either similar or slightly lower than systemic exposure after indacaterol 150 mcg monotherapy product inhalation.

Absolute bioavailability of indacaterol after ULTIBRO BREEZHALER 110/50 mcg inhalation ranged from 47% to 66% whereas that of glycopyrronium was about 40%.

The steady-state exposure to glycopyrronium after ULTIBRO BREEZHALER 110/50 mcg inhalation was similar to systemic exposure after glycopyrronium 50 mcg monotherapy product inhalation.

Absorption

Indacaterol: The absolute bioavailability of inhaled indacaterol was 43-45%. Systemic exposure results from a composite of pulmonary and intestinal absorption and increases with increasing dose. Indacaterol serum concentrations increased with repeated once-daily administration. Steady-state was achieved within 12 to 15 days.

Glycopyrronium: The absolute bioavailability of inhaled glycopyrronium was estimated to be about 40%. About 90% of systemic exposure following inhalation is due to lung absorption and 10% is due to gastrointestinal absorption. Following repeated once-daily inhalation in patients with COPD, the pharmacokinetic (PK) steady-state of glycopyrronium was reached within one week of treatment.

Distribution

Indacaterol: After intravenous infusion the volume of distribution (V_z) of indacaterol was 2,361 to 2,557 L indicating an extensive distribution. The *in vitro* human serum and plasma protein binding was 94.1 to 95.3% and 95.1 to 96.2%, respectively.

Glycopyrronium: After i.v. dosing, the steady-state volume of distribution (V_{ss}) of glycopyrronium was 83 L and the volume of distribution in the terminal phase (V_z) was 376 L. The apparent volume of distribution in the terminal phase following inhalation (V_z/F) was 7310 L, which reflects the much slower elimination after inhalation. The *in vitro* human plasma protein binding of glycopyrronium was 38% to 41%.

Metabolism

Indacaterol: After oral administration of radiolabelled indacaterol, unchanged indacaterol was the main component in human serum, accounting for about one third of total drug-related AUC over 24 h. A hydroxylated derivative, possibly via CYP3A4, was the most prominent metabolite in serum. Indacaterol is a low affinity substrate for the efflux pump P-gp.

Glycopyrronium: *In vitro* investigations showed that multiple CYP isoenzymes contribute to the oxidative biotransformation of glycopyrronium. Glycopyrronium was not shown to inhibit or induce cytochrome P450 isoenzymes.

Excretion

Indacaterol: Renal clearance plays a minor role (about 2 to 6% of systemic clearance) in the elimination of systemically available indacaterol. The fecal route of excretion was dominant over the urinary route. Indacaterol was excreted into human feces primarily as unchanged parent drug (54% of the dose) and, to a lesser extent, hydroxylated indacaterol metabolites (23% of the dose).

Glycopyrronium: Renal elimination of parent drug accounts for about 60 to 70% of total clearance of systemically available glycopyrronium whereas non-renal clearance processes account for about 30 to 40%. Biliary clearance contributes to the non-renal clearance, but the majority of non-renal clearance is thought to be due to metabolism.

Following inhalation of single and repeated once-daily doses between 50 and 200 mcg glycopyrronium by healthy volunteers and patients with COPD mean renal clearance of glycopyrronium was in the range of 17.4 and 24.4 L/h. Active tubular secretion contributes to the renal elimination of glycopyrronium. Up to 20% of the dose was found in urine as parent drug.

Special Populations and Conditions

Pediatrics: ULTIBRO BREEZHALER is not indicated for use in children and therefore should not be used in patients under 18 years of age.

Geriatrics: ULTIBRO BREEZHALER can be used at the recommended dose in elderly patients 65 years of age and older.

Gender: A population PK analysis in COPD patients after inhalation of ULTIBRO BREEZHALER indicated no significant effect of age, gender and (lean body) weight on the systemic exposure to indacaterol and glycopyrronium. Lean body weight (which is a function of weight and height) was identified as a covariate. A negative correlation between systemic exposure and lean body-weight (or body weight) was observed; however, no dose adjustment is recommended due to the magnitude of the change or the predictive precision of lean body weight.

Race: Limited treatment experience is available for the African-American population. No difference between ethnic subgroups was identified for indacaterol. An ethnic sensitivity study conducted in Japanese and Caucasian healthy volunteers showed peak plasma exposure of glycopyrronium was on average 80% higher and total systemic exposure (AUC) and urinary excretion were 38 to 46% higher in Japanese than in Caucasian volunteers. The renal clearance (CL_r) was similar for both populations.

Hepatic impairment: Based on the clinical PK characteristics of its monotherapy components, ULTIBRO BREEZHALER can be used at the recommended dose in patients with mild and moderate hepatic impairment. No data are available for subjects with severe hepatic impairment.

Renal impairment: Based on the clinical PK characteristics of its monotherapy components, ULTIBRO BREEZHALER can be used at the recommended dose in patients with mild to moderate renal impairment. In patients with severe renal impairment or end-stage renal disease requiring dialysis ULTIBRO BREEZHALER should be used only if the expected benefit outweighs the potential risk.

STORAGE AND STABILITY

Store ULTIBRO BREEZHALER at room temperature between 15-25°C. Do not store above 25°C and protect from moisture.

ULTIBRO BREEZHALER must be kept out of the reach and sight of children.

SPECIAL HANDLING INSTRUCTIONS

- ULTIBRO BREEZHALER capsules should be used with the ULTIBRO BREEZHALER inhalation device only. The ULTIBRO BREEZHALER inhalation device should not be used with any other capsules.
- Capsules should always be stored in the blister and only removed from the blister immediately before use.

- Always use the new ULTIBRO BREEZHALER inhalation device provided with each new prescription and discard the old device.

DOSAGE FORMS, COMPOSITION AND PACKAGING

ULTIBRO BREEZHALER (indacaterol/glycopyrronium) 110/50 mcg, inhalation powder hard capsules.

110/50 mcg ULTIBRO BREEZHALER contains: Aluminium blister-packaged indacaterol and glycopyrronium (as indacaterol maleate and glycopyrronium bromide) Transparent yellow cap and natural transparent body capsules containing a white to practically white powder, with the product code IGP110.50 printed in blue under two blue bars on body and the company logo (♯) printed in black on cap.

Each capsule contains 143 mcg indacaterol maleate equivalent to 110 mcg indacaterol and 63 mcg glycopyrronium bromide equivalent to 50 mcg glycopyrronium.

The delivered dose (the dose that leaves the mouthpiece of the inhaler) is equivalent to 85 mcg indacaterol and 43 mcg glycopyrronium.

Each capsule also contains lactose monohydrate and magnesium stearate.

The capsule shell components are hypromellose, purified water, carrageenan, potassium chloride, FD&C Yellow5/Tartrazine.

The following pack types are available:

- Carton of 30 ULTIBRO BREEZHALER capsules (3 blister cards of 10 capsules) and one ULTIBRO BREEZHALER device.
- Carton of 10 ULTIBRO BREEZHALER capsules (1 blister card of 10 capsules) and five ULTIBRO BREEZHALER devices.

PART II: SCIENTIFIC INFORMATION

PHARMACEUTICAL INFORMATION

Drug Substance

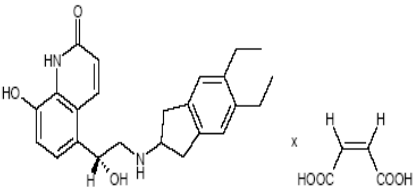
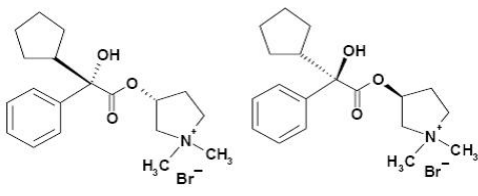
Common name:	
indacaterol maleate	Glycopyrronium bromide
Chemical name:	
(R)-5-[2-(5,6-Diethylindan-2-ylamino)-1-hydroxyethyl]-8-hydroxy-1H-quinolin-2-one maleate	3-(2-Cyclopentyl-2-hydroxy-2-phenylacetoxy)-1,1-dimethylpyrrolidinium bromide
Molecular formula and molecular mass	
$C_{24}H_{28}N_2O_3 \cdot C_4H_4O_4$ (508.56)	$C_{19}H_{28}NO_3$ Br Salt form on anhydrous basis: 398.33
Structural formula:	
	
Physicochemical properties:	
<p>Indacaterol is the pure R-enantiomer of this molecule.</p> <p>Indacaterol maleate consists of a single polymorphic form, form A.</p> <p>The pH of indacaterol maleate in 0.1% (g/100 ml) suspension in water at room temperature is 4.9. The pH value of 0.1% (g/100 ml) solution in water/ethanol 80:20 (V/V) at room temperature is 5.0.</p> <p>The melting range of indacaterol is 195 – 202°C with decomposition.</p> <p>Indacaterol maleate is a white to very slightly grayish or very slightly yellowish powder. Indacaterol maleate is freely soluble in N-methylpyrrolidone and dimethylformamide, slightly soluble in methanol, ethanol, propylene glycol and polyethylene glycol 400, very slightly soluble in water, isopropyl alcohol and practically insoluble in 0.9% sodium chloride in water, ethyl acetate and n-octanol.</p>	<p>The drug substance glycopyrronium bromide presents 2 asymmetric carbon atoms and is an optically inactive racemic mixture of 2 stereoisomers (2S, 3R and 2R, 3S), hereafter referred to as the stereoisomers (S,R) and (R,S).</p> <p>The pH of glycopyrronium bromide in 1.0% m/V (g/100 mL) solution in water at room temperature is 6.0.</p> <p>Melting range: 193 – 198 °C (but the range between beginning and end of melting does not exceed 2 °C).</p> <p>Glycopyrronium bromide is a white to practically white powder. Glycopyrronium bromide is freely soluble in water, 0.9% sodium chloride in water, methanol, ethanol (50% and 95%), soluble in N,N-Dimethylformamide, sparingly soluble in Ethanol (≥ 99.9 %), 1-Propanol, slightly soluble in 2-Propanol, 1-Octanol, acetonitrile, very slightly soluble in acetone and practically insoluble in toluene, Tetrahydrofuran and tert-Butyl methyl ether.</p>

Drug Product

ULTIBRO BREEZHALER 110/50 mcg inhalation powder, hard capsules:

Each capsule contains 143 mcg indacaterol maleate equivalent to 110 mcg indacaterol and 63 mcg glycopyrronium bromide equivalent to 50 mcg glycopyrronium. The delivered dose (the dose that leaves the mouthpiece of the inhaler) is equivalent to 85 mcg indacaterol and 43 mcg glycopyrronium.

ULTIBRO BREEZHALER INHALATION DEVICE

The ULTIBRO BREEZHALER is a plastic inhalation device used for inhaling the content of ULTIBRO BREEZHALER (indacaterol maleate and glycopyrronium bromide) capsules. The amount of drug delivered to the lung will depend on patient factors, such as inspiratory flow rate and inspiratory time.

CLINICAL TRIALS

The safety and efficacy of ULTIBRO BREEZHALER were evaluated in a clinical development program that included 2 lung function studies of 26 weeks duration (1 placebo controlled and one active controlled) in patients with moderate to severe COPD, a 64 week and a 52 week exacerbation study, a 12-month long-term safety study, and an exercise tolerance study.

Table 4 Summary of trial design and patient demographics for pivotal clinical trials

Study #	Trial design, route of administration and study duration	Treatment and Dosage	Study subjects (n=number) Mean age (Range) Gender	Primary Efficacy Endpoint
A2303	A 26-week multi-centre, randomized, double-blind, parallel-group, placebo and active controlled (open label) study to assess the efficacy, safety and tolerability of ULTIBRO BREEZHALER in patients with moderate to severe chronic obstructive pulmonary disease (COPD)	ULTIBROBREEZHALER 110 mcg/50 mcg o.d. Indacaterol 150 mcg o.d. Glycopyrronium 50 mcg o.d. Open Label Tiotropium 18 mcg o.d. Placebo	Total: n = 2135 ULTIBRO BREEZHALER: n = 474 Indacaterol: n = 476 Glycopyrronium: n = 473 Open Label Tiotropium: n = 480 Placebo: n = 232 <u>Mean age (Range)</u> 63.9 years (40 – 91) <u>Gender</u> Male: 1610 Female: 525	Post-dose trough Forced Expiratory Volume In One Second (FEV ₁), (mean of 23 h 15 min and 23 h 45 min post-dose) following 26 weeks of treatment in patients with moderate to severe COPD
A2313	A 26-week treatment, multi-center, randomized, double-blind, double dummy, parallel-group study to assess the efficacy, safety and tolerability of ULTIBRO BREEZHALER in patients with moderate to severe chronic obstructive pulmonary disease.	ULTIBROBREEZHALER 110 mcg/50 mcg q.d Fluticasone/salmeterol 500 mcg/50 mcg b.i.d	Total: n = 522 ULTIBRO BREEZHALER: n = 258 Fluticasone/salmeterol: n = 264 <u>Mean age (Range)</u> 63.3 years (44 – 87) <u>Gender</u> Male: 370 Female: 152	Standardized FEV ₁ AUC _{0-12h} following 26 weeks of treatment in patients with moderate to severe COPD.

A2304	A multi-center, randomized, double-blind, parallel-group, active-controlled (open-label) study from 64 to 76 weeks to evaluate the effect of ULTIBRO BREEZHALER on COPD exacerbations in patients with severe to very severe COPD.	ULTIBRO BREEZHALER 110 mcg/50 mcg o.d. Glycopyrronium 50 mcg o.d. Open Label Tiotropium 18 mcg o.d.	Total: n = 2206 ULTIBRO BREEZHALER: n = 729 Glycopyrronium: n = 740 Open Label Tiotropium: n = 737 <u>Mean age (Range)</u> 63.3 years (40 – 90) <u>Gender</u> Male: 1651 Female: 555	Rate of moderate or severe COPD exacerbations in patients with severe to very severe COPD.
A2318	A 52-week treatment, multi-center, randomized, double-blind, double dummy, parallel-group, active-controlled study to evaluate the effect of ULTIBRO BREEZHALER compared to fluticasone/salmeterol (500/50 mcg b.i.d.) on exacerbations (mild/moderate/severe) in patients with moderate to very severe COPD	ULTIBRO BREEZHALER 110 mcg/50 mcg q.d Fluticasone/salmeterol 500 mcg/50 mcg b.i.d	Total: n = 3362 ULTIBRO BREEZHALER: n = 1680 Fluticasone/salmeterol: n = 1682 <u>Mean age (Range)</u> 64.6 years (40 – 89) <u>Gender</u> Male: 2557 Female: 805	Rate of COPD exacerbations (mild/moderate/severe) in patients with moderate to very severe COPD

Lung Function Clinical Trials

The efficacy and safety of ULTIBRO BREEZHALER were evaluated in two pivotal efficacy trials in patients with a clinical diagnosis of moderate-to-severe COPD; Trial A2303 (placebo controlled), and Trial A2313 (active-controlled).

Study design

Trial A2303 was designed to evaluate the efficacy of ULTIBRO BREEZHALER in improving lung function following 26 weeks of treatment in comparison with the individual monotherapy

components, indacaterol and glycopyrronium, and placebo. The primary end-point was the post-dose trough Forced Expiratory Volume in one second (FEV₁) following 26 weeks of treatment in patients with moderate to severe COPD, Transitional Dyspnea Index (TDI) focal score, St. George's Respiratory Questionnaire (SGRQ) and daily rescue medication use at Week 26, were also captured as key secondary efficacy endpoints.

Trial A2313 was designed to evaluate the efficacy of ULTIBRO BREEZHALER in improving lung function following 26 weeks of treatment versus an active comparator (Table 4).

Both trials were randomized, double-blind, parallel-group studies with generally similar inclusion/exclusion criteria (in study A2313, patients were excluded if they had an exacerbation in the past 12 months) and concomitant medications (in study A2313, use of inhaled corticosteroids as background therapy was not allowed).

Patient Demographics and Baseline Characteristics

A total of 2657 subjects were randomized and received treatments in the two pivotal studies (Table 4). The subjects had a clinical diagnosis of COPD, were 40 years of age or older, had a history of smoking greater than 10 pack-years, had moderate-to-severe airflow obstruction (a post-salbutamol FEV₁ of ≤ 30 and ≤ 80 of predicted normal values (A2303) or ≤ 40 and ≤ 80 (A2313) and a ratio of FEV₁/FVC < 0.7).

In Study A2303, patients were allowed to continue on their background inhaled corticosteroids at the same fixed dose, whereas in Study A2313, ICS use was discontinued during the baseline period. Both studies allowed use of rescue medication (salbutamol). LAMAs and LABAs were not allowed in the study.

The most important exclusion criteria were patients who had a COPD exacerbation and required treatment with antibiotics, systemic corticosteroids or hospitalization in the 6 weeks prior to screening or during the baseline period in Study A2303. In Study A2313, patients were excluded if they had an exacerbation 12 months prior to screening or during the baseline period.

The majority of the 2657 patients recruited in the 26 week pivotal trials were male (74.5 %), white (71.9%), with a mean age of 63.8 years. At baseline, the mean post-bronchodilator FEV₁ was 1.539 L (GOLD II [66.9%], GOLD III [33.0%], GOLD IV [0%]). Mean β_2 -agonist reversibility was 20.28%.

Study Results

Study A2303

Lung Function

The placebo-controlled study, A2303, evaluated the efficacy of ULTIBRO BREEZHALER administered at 110/50 mcg compared with indacaterol 150 mcg[^], glycopyrronium 50 mcg, and placebo, all administered once daily. At week 26, patients receiving ULTIBRO BREEZHALER had a greater increase in trough FEV₁ compared with those receiving indacaterol 150 mcg (70 mL; 95% CI=50, 100; p<0.001) and glycopyrronium 50 mcg (90 mL; 95% CI=60, 110; p<0.001), suggesting a contribution of indacaterol and glycopyrronium to the improvement of

lung function (Table 5). The difference from placebo was 200 mL (95% CI=170, 240; p<0.001) (Table 5).

^In order to match the fine particle dose of indacaterol in both the combination and the 150 mcg monotherapy product, the dose of indacaterol in ULTIBRO BREEZHALER was adjusted to 110 mcg.

Table 5 Primary efficacy endpoint at Week 26 for treatment with ULTIBRO BREEZHALER in Study A2303

	Primary Endpoint		
	Trough FEV₁ (mL) at Week 26		
	Treatment Difference	95% CI	p-value
ULTIBRO BREEZHALER - indacaterol	70 mL	(50, 100)	p<0.001
ULTIBRO BREEZHALER - glycopyrronium	90 mL	(60, 110)	p<0.001
ULTIBRO BREEZHALER - placebo	200 mL	(170, 240)	p<0.001
Abbreviations: CI=confidence interval; FEV1=forced expiratory volume in 1 second;			

Figure 1 23 h 45 min profile of least squares means of FEV₁ (L) after 26 weeks of treatment (FAS, serial spirometry subset) in Study A2303

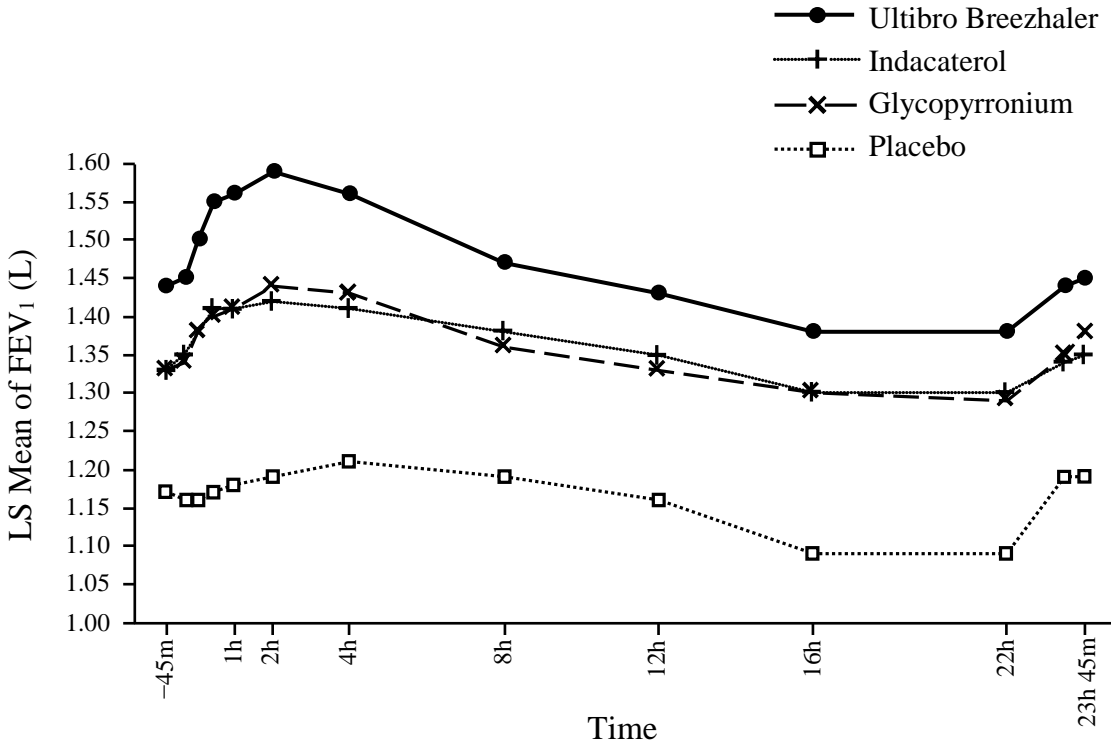

In the A2303 serial spirometry subset (Figure 1), ULTIBRO BREEZHALER was consistently superior to placebo in FEV₁ at all assessed time points at Week 26 (LS mean differences 250-400 mL).

Over the entire treatment period of 26 weeks (Figure 2), ULTIBRO BREEZHALER demonstrated significant improvement in FEV₁ with no attenuation of the bronchodilatory response.

Figure 2 Least squares means of FEV₁ (L) over 26 weeks of treatment (FAS, all patients) in Study A2303

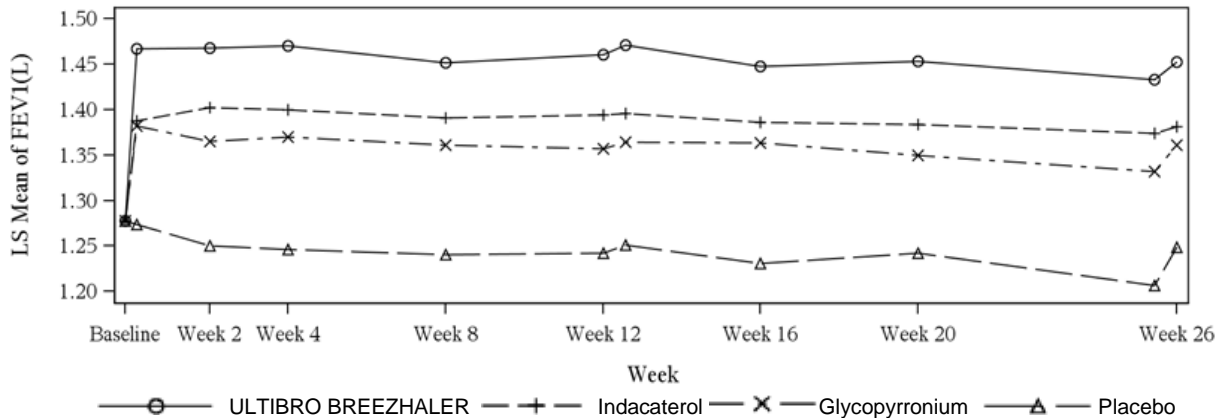

Symptom Related Outcomes

ULTIBRO BREEZHALER reduced shortness of breath, as measured by the treatment difference in TDI focal score at Week 26 compared to placebo (1.09 units, 95% CI CI=0.61, 1.57, $p<0.001$).

Health-related quality of life was measured using St. George's Respiratory Questionnaire (SGRQ). Following 26 weeks of treatment, the mean difference from baseline in SGRQ total score between ULTIBRO BREEZHALER and placebo was -3.01 units (95% CI CI=-5.05, -0.97, $p=0.002$).

Use of rescue medication

Over 26 weeks, ULTIBRO BREEZHALER once daily reduced the use of rescue medication (salbutamol) by 0.96 puffs per day compared to placebo ($p<0.001$).

Study A2313

The results from the active controlled study, A2313, provided additional support for the efficacy of ULTIBRO BREEZHALER (data not shown).

Exacerbation Clinical Trials

The effect of ULTIBRO BREEZHALER on COPD exacerbations were evaluated in two active-controlled pivotal trials in patients with a clinical diagnosis of moderate-to-very severe COPD; Study A2304 and Study A2318.

Study design

Study A2304, was a 64-week, randomized, double-blind parallel-group study comparing the effects of ULTIBRO BREEZHALER 110/50 mcg (n=729), glycopyrronium 50 mcg (n=740) and open-label tiotropium 18 mcg (n=737), all administered once daily, in patients with severe to very severe COPD (Gold III: 1743 patients; Gold IV: 461 patients). The primary efficacy endpoint was the rate of moderate to severe COPD exacerbations. A COPD moderate/severe exacerbation was defined as worsening symptoms that required treatment with systemic glucocorticosteroids and/or antibiotics or in-patient hospitalisation. A COPD exacerbation was considered of moderate severity if treatment with systemic glucocorticosteroids or antibiotics or both was required; and severe, if hospitalization was required. Study A2304 enrolled severe to very severe COPD patients with a history of ≥ 1 COPD exacerbation which required treatment with antibiotics and/or steroids (22% had a history of ≥ 2 exacerbations) in the previous year, a post-bronchodilator FEV₁ of $< 50\%$ of the predicted normal value, and post-bronchodilator FEV₁/FVC < 0.7 .

Study A2318 was a 52-week, randomized, double-blind, double dummy, parallel-group, active-controlled study comparing the effects of ULTIBRO BREEZHALER 110/50 mcg once-daily (n=1680) and fluticasone/salmeterol 500/50 mcg twice-daily (n=1682), in patients with moderate

to very severe COPD (Gold II: 1123 patients; Gold III: 1954 patients; Gold IV: 257 patients). The primary efficacy endpoint was the rate of all COPD exacerbations (mild, moderate, or severe). A COPD exacerbation was defined as worsening symptoms that required treatment with systemic glucocorticosteroids and/or antibiotics or in-patient hospitalisation. A COPD exacerbation was considered of mild severity if a worsening of symptoms that met the symptom criteria that was not treated with systemic corticosteroids and/or antibiotics; moderate, if a worsening of symptoms that met the symptom criteria that was treated with systemic glucocorticosteroids or antibiotics or both; and severe, if hospitalization was required. Study A2318 enrolled moderate to very severe COPD patients with a history of ≥ 1 COPD exacerbation requiring systemic glucocorticosteroids and/or antibiotics (19% had a history of ≥ 2 exacerbations) in the previous year, and a post-bronchodilator FEV₁ of ≥ 25 and $< 60\%$ of the predicted normal value.

Exacerbation results

In Study A2304, ULTIBRO BREEZHALER reduced the annual rate of moderate or severe COPD exacerbations by 12% compared to glycopyrronium (Risk ratio:0.88, 95% CI=0.77, 0.99). The number of moderate or severe COPD exacerbations/patient-years was 0.94 for ULTIBRO BREEZHALER (812 events) vs. 1.07 for glycopyrronium (900 events).

In addition, ULTIBRO BREEZHALER reduced the rate of all COPD exacerbations (mild, moderate, and severe), with a rate reduction of 15% for ULTIBRO BREEZHALER as compared to glycopyrronium (Risk ratio: 0.85, 95% CI=0.77, 0.94).

For time to first moderate or severe COPD exacerbation, ULTIBRO BREEZHALER demonstrated a 7% risk reduction compared to glycopyrronium (p=0.319).

The results of Study A2318 showed that ULTIBRO BREEZHALER once daily met the primary study objective of non-inferiority in rate of all COPD exacerbations (mild, moderate, or severe) compared to fluticasone/salmeterol. ULTIBRO BREEZHALER further showed superiority in reducing the annualized rate of all exacerbations by 11% versus fluticasone/salmeterol (3.59 vs. 4.03; rate ratio, 0.89; 95% confidence interval [CI], 0.83 to 0.96, p=0.003), and prolonged time-to-first exacerbation with a 16% reduction in risk of an exacerbation (median time: 71 days for ULTIBRO BREEZHALER vs. 51 days for fluticasone/salmeterol, p<0.001). ULTIBRO BREEZHALER reduced the annualized rate of moderate or severe exacerbations by 17% versus fluticasone/salmeterol (0.98 vs. 1.19, rate ratio, 0.83; 95% CI, 0.75 to 0.91, p<0.001). The time to the first moderate or severe exacerbation was longer in ULTIBRO BREEZHALER group than that in the fluticasone/salmeterol (hazard ratio, 0.78; 95% CI, 0.70 to 0.86; P<0.001) with a 22% reduction in risk of an exacerbation.

Exercise tolerance

In a 3-week, 3-period, cross-over study (n=85) (A2305) where exercise tolerance was conducted via cycle ergometry at submaximal (75%) workload (submaximal exercise tolerance test), ULTIBRO BREEZHALER 110/50 mcg once-daily, dosed in the morning, was compared to placebo and tiotropium 18 mcg once-daily. ULTIBRO BREEZHALER reduced dynamic hyperinflation and improved the length of time exercise could be maintained from the first dose

onwards. Exercise endurance time was increased by 59.5 seconds (95% CI=17.7, 101.3) compared to placebo.

DETAILED PHARMACOLOGY

Animal Pharmacology

Indacaterol: Indacaterol is a nearly full potent beta₂ adrenoceptor agonist (EC₅₀ value of 8.7 nM) with high intrinsic activity.

A fast onset and a longer duration of action with the potential for once daily dosing was demonstrated in *in vitro* models. The mechanism responsible for the long duration of action of indacaterol has not been unequivocally established. However, it is likely related to its lipophilicity and its specific interaction with the lipid raft within the cellular membrane.

Glycopyrronium: Glycopyrronium bromide is a competitive, high affinity muscarinic receptor antagonist. It demonstrated 4- to 5-fold selectivity for the human M3 (pK_i value: 9.59) and M1 receptors over the human M2 receptor in competition binding studies. It has a rapid onset of bronchodilatory action and this effect is maintained 24h post-dose.

TOXICOLOGY

Information related to ULTIBRO BREEZHALER

A bridging toxicology programme was performed for ULTIBRO BREEZHALER that included *in vitro* and *in vivo* safety pharmacology assessments, repeated-dose inhalation toxicity studies in rats and dogs and an inhalation embryo-foetal development study in rats.

Increased heart rates were apparent in dogs after the administration of each individual monotherapy and the indacaterol/glycopyrronium combination. The effects on heart rate for indacaterol/glycopyrronium increased in magnitude and duration when compared with the changes observed for each component alone consistent with an additive response. Shortening of electrocardiograph intervals that reflected increased heart rate and decreased systolic and diastolic blood pressure were also apparent following treatment with the combination. Indacaterol administered to dogs alone or in the indacaterol/glycopyrronium combination was associated with a similar incidence and severity of myocardial lesions. Systemic exposures (AUC) at the no-observed-adverse-effect level (NOAEL) were 64- and 59-fold higher than in humans at a dose of 110 mcg/50 mcg, for each component respectively.

No effects on the embryo or foetus were seen at any dose level of indacaterol/glycopyrronium during an embryo-foetal development study in rats.

Table 6 Repeat-dose Toxicity

Study Type	Species	Route	Doses (mcg/kg/day)	Primary findings
2-week with 4-week recovery	Wistar Rat	Inhalation	indacaterol/ glycopyrronium 100.6/32.9 200.5/65.6 402.3/131.6 Indacaterol 479.2/0 Glycopyrronium 0/169.8	No relevant treatment-related effects were observed.
2-week with 2-week recovery	Beagle Dog	Inhalation	indacaterol/ glycopyrronium 101/34 193/62 380/126 Indacaterol 416/0 Glycopyrronium 0/123	indacaterol/glycopyrronium and indacaterol: minimal to moderate papillary muscle fibrosis in the left ventricle of individual animals. Minimal glycogen accumulation in the liver. Heart and liver findings were no longer apparent on completion of the recovery period. indacaterol/glycopyrronium, indacaterol and glycopyrronium: increased heart rates 30 and 60 min post-dose in all dose groups. Additive effects on heart rate were apparent for indacaterol/glycopyrronium. Heart rates returned to normal 24 hours post-dose.
13-week with 4-week recovery	Beagle Dog	Inhalation	indacaterol/ glycopyrronium 99/33 211/70 386/125 Indacaterol 343/0 Glycopyrronium 0/140	indacaterol/glycopyrronium and indacaterol: minimal, reversible glycogen accumulation in the liver. This finding was no longer apparent on completion of the recovery period indacaterol/glycopyrronium, indacaterol and glycopyrronium: low-dose indacaterol/glycopyrronium resulted in increases in heart rate that were similar to indacaterol or glycopyrronium treatment alone. Additive effects on heart rate were apparent for indacaterol/glycopyrronium at the mid and high dose levels. Heart rates returned to normal 24 hours post-dose.

Information related to indacaterol

Non-clinical data reveal no special hazard for humans based on conventional studies of safety pharmacology, repeated-dose toxicity, genotoxicity, carcinogenic potential, and toxicity to reproduction.

The effects of indacaterol seen in toxicity studies in dogs were mainly on the cardiovascular system and consisted of tachycardia and associated increased QTc intervals, arrhythmias and myocardial lesions. These are known pharmacological effects and could be explained by the beta₂-agonistic properties of indacaterol. Other relevant effects noted in repeated-dose toxicity studies at exposures in excess of the maximum human exposure were mild irritancy of the upper respiratory tract in rats consisting of rhinitis and epithelial changes of the nasal cavity and larynx.

Studies on genotoxicity did not reveal any mutagenic or clastogenic potential. The carcinogenic potential of indacaterol was evaluated in a 2-year inhalation study in rats and a 26-week oral transgenic mouse study. Lifetime treatment of rats at high doses of indacaterol resulted in increased incidences of benign ovarian leiomyoma and focal hyperplasia of ovarian smooth muscle. Increases in leiomyomas of the rat female genital tract have been similarly demonstrated

with other beta₂-adrenergic agonist drugs. A 26-week oral study in CB6F1/TgrasH2 hemizygous mice with indacaterol did not show any evidence of tumorigenicity.

Toxicity effects with respect to fertility, pregnancy, embryonal/foetal development, pre- and postnatal development demonstrated only at high doses. Indacaterol was not teratogenic in rats or rabbits following subcutaneous administration. Indacaterol and its metabolites were shown to cross the placental barrier of pregnant rats and were also detected in the milk of lactating rats.

Information related to glycopyrronium

Non-clinical data reveal no special hazard for humans based on conventional studies of safety pharmacology, repeated-dose toxicity, genotoxicity, carcinogenic potential, and toxicity to reproduction and development.

The effects seen during repeated-dose inhalation toxicity studies were attributable to exacerbations of the expected pharmacological action of glycopyrronium or mild local irritation. These included mild to moderate increases in heart rate in dogs and a number of reversible changes in rat and dogs associated with reduced secretions from the salivary, lacrimal and Harderian glands and pharynx. Lens opacities observed during chronic studies in rats have been described for other muscarinic antagonists and are considered to be species-specific changes with limited relevance for therapeutic use in patients. Findings in the respiratory tract of rats included degenerative/regenerative changes and inflammation in the nasal cavity and larynx that are consistent with mild local irritation. Minimal epithelial changes in the lung at the bronchioloalveolar junction were also observed in rats and are regarded as a mild adaptive response. All these findings were observed at exposures considered to be sufficiently in excess of the maximum human exposure.

Genotoxicity studies did not reveal any mutagenic or clastogenic potential for glycopyrronium. Carcinogenicity studies in transgenic mice using oral administration and in rats using inhalation administration revealed no evidence of carcinogenicity at systemic exposures in excess of the maximum human exposure.

Reproduction studies in rats regarding fertility in either males or females or pre- and post-natal development did not reveal many significant events following subcutaneous administration. There were however slight but statistically significant decreases in the number of corpora lutea and implantation sites in females at 1.5 mg/kg/day which were attributed to glycopyrronium bromide. Also, significantly lower pup body weights in the F1 generation (male, female, and genders combined) and growth during the lactation period were seen at 1.5 mg/kg/day. Diminished rates of conception and of survival at weaning in rats and reduced seminal secretion in dogs have been reported following subcutaneous administration of glycopyrronium bromide at high dose levels. Glycopyrronium and its metabolites did not significantly cross the placental barrier of pregnant mice, rabbits and dogs. Glycopyrronium (including its metabolites) was excreted into the milk of lactating rats and reached up to 10-fold higher concentrations in the milk than in the blood of the dam.

REFERENCES

1. Product Monograph: Onbrez Breezhaler. Long-acting beta₂-agonist. Novartis Pharmaceuticals Canada Inc. Montreal, Canada. January 2, 2015
2. Product Monograph: Seebri Breezhaler. Long-acting muscarinic antagonist. Novartis Pharmaceuticals Canada Inc. Montreal, Canada. September 29, 2016

PART III: CONSUMER INFORMATION

PrULTIBRO® BREEZHALER®

**Indacaterol (as maleate)/glycopyrronium (as bromide)
inhalation powder hard capsules**

Read this carefully before you start taking **ULTIBRO BREEZHALER** and each time you get a refill. This leaflet is a summary and will not tell you everything about **ULTIBRO BREEZHALER**. Talk to your doctor, nurse, or pharmacist about your medical condition and treatment and ask if there is any new information about **ULTIBRO BREEZHALER**.

ABOUT THIS MEDICATION

What the medication is used for:

ULTIBRO BREEZHALER is used long term once daily to treat breathing difficulties due to a lung disease called chronic obstructive pulmonary disease (COPD). It is also used to reduce the likelihood of “flare-ups” in people with COPD who have previously had these events.

In COPD, a “flare-up” is when your condition is getting worse. You will know you are having a “flare-up” if two of the following symptoms get worse for more than two days:

- Unusual increase in the severity of breathlessness; cough, wheezing, or fatigue;
- Unusual colour, amount or thickness of mucus;
- Tightness in the chest or symptoms of a cold.

ULTIBRO BREEZHALER is not for treating sudden, severe symptoms of COPD.

What it does:

ULTIBRO BREEZHALER contains two active substances called indacaterol and glycopyrronium.

- Indacaterol is a long-acting beta₂ agonist (LABA)
- Glycopyrronium is a long-acting muscarinic antagonist (LAMA)

Both active ingredients belong to a group of medicines called bronchodilators. They help to open and relax the muscles of the airways. This allows more air to get in and out of the lungs and helps prevent shortness of breath and wheezing.

This medicine does not cure COPD but helps to control it. It is therefore important that you take **ULTIBRO BREEZHALER** regularly even if you feel fine.

When it should not be used:

Do not use **ULTIBRO BREEZHALER:**

- **If you have a severe allergy to indacaterol maleate or glycopyrronium bromide or any other component of **ULTIBRO BREEZHALER**. Ask your doctor, nurse or pharmacist if you are not sure.**
- **To treat sudden, severe symptoms of COPD such as**

sudden shortness of breath or wheezing.

- **To treat asthma.**
- **ULTIBRO BREEZHALER should not be used in children. COPD does not occur in children.**
- **If you have a lactose or severe milk protein allergy.**
- **If you are younger than 18 years of age.**

What the medicinal ingredient is:

Indacaterol maleate and glycopyrronium bromide

What the non-medicinal ingredients are:

Carrageenan, FD&C Yellow 5/Tartrazine, hypromellose, lactose monohydrate (which contains milk proteins), magnesium stearate, potassium chloride, purified water.

What dosage forms it comes in:

Transparent yellow capsules for oral **inhalation**. Each capsule contains 110 mcg indacaterol and 50 mcg glycopyrronium.

Each pack includes an inhaler and capsules (in blister strips) that contain the medicine as inhalation powder.

WARNINGS AND PRECAUTIONS

Serious Warnings and Precautions

ULTIBRO BREEZHALER should only be used to treat COPD.

ULTIBRO BREEZHALER should not be used to treat asthma.

You are advised that in patients with asthma, long-acting beta₂-agonist (LABA) medicines, may increase the chance of death from asthma problems. In a large asthma study, more patients who used another LABA medicine (salmeterol) died from asthma problems compared with patients who did not use that LABA medicine. This finding with salmeterol is considered a class effect of LABA, including indacaterol maleate, one of the active ingredients of **ULTIBRO BREEZHALER**.

BEFORE you use **ULTIBRO BREEZHALER talk to your doctor, nurse or pharmacist if you:**

- Are pregnant or planning to become pregnant;
- Are a breast-feeding mother;
- Are an asthmatic (in this case you should not be treated with **ULTIBRO BREEZHALER**);
- Have heart problems, such as rapid or irregular heart beat or abnormal electrical signal called “prolongation of the QT interval”;
- Have high blood pressure;
- Have seizures or fits;
- Have thyroid gland problems or disease;

- Suffer from diabetes;
- Are taking similar medicines for your lung disease;
- Are taking any medications including eye drops, this includes medications you can buy without prescription;
- Have problems with your kidneys;
- Have severe liver problems;
- Have eye problems, such as glaucoma or eye pain, blurred vision, see halos around lights or coloured images;
- Have an enlarged prostate, problems passing urine, or painful urination;
- Have a severe allergy to milk proteins. Ask your doctor if you are not sure;
- Have had allergies to atropine or related medicines, for example ipratropium or tiotropium;
- Have allergies to food or drugs.

These capsules are intended for inhalation only.

DO NOT SWALLOW.

ULTIBRO BREEZHALER should not be used more frequently than once daily. Do not exceed the prescribed dose.

This medication has been prescribed for you and should not be given to other people.

Avoid getting the drug powder into your eyes. This may result in eye pain and/or discomfort, temporary blurring of vision, and/or coloured images in association with red eyes. These may be signs of acute narrow-angle glaucoma. Should any of these symptoms develop, consult a doctor immediately.

Remember to tell any other doctor, nurse, dentist or pharmacist you consult that you are taking this medication.

Driving and Using Machines:

The occurrence of dizziness or blurred vision may influence the ability to drive and use machinery.

During the treatment with ULTIBRO BREEZHALER, tell your doctor immediately if you experience any of the following symptoms:

- **stop taking ULTIBRO BREEZHALER and tell your doctor immediately** if you experience a tightness of the chest, coughing, wheezing or breathlessness immediately after inhalation of ULTIBRO BREEZHALER (signs of paradoxical bronchospasm).
- **stop taking ULTIBRO BREEZHALER and tell your doctor immediately** if you experience difficulties in breathing or swallowing, swelling of tongue, lips and face, hives or itching, skin rash (signs of hypersensitivity reaction). Do not use ULTIBRO BREEZHALER again before speaking with your doctor.
- If your COPD symptoms (breathlessness, wheezing, cough) do not improve or if they worsen during your treatment.
- **stop taking ULTIBRO BREEZHALER and tell your doctor immediately** if you experience eye pain or discomfort,

temporary blurring of vision, visual halos or colored images in association with red eyes; these may be signs of an acute attack of narrow-angle glaucoma.

ULTIBRO BREEZHALER does not relieve sudden symptoms of COPD. Always have a short-acting bronchodilator medicine with you to treat acute symptoms. If you do not have an inhaled, short-acting bronchodilator, contact your healthcare provider to have one prescribed for you.

Get emergency medical care if:

- breathing problems worsen quickly
- you use your short-acting bronchodilator medicine, but it does not relieve your breathing problems

Ask your doctor, nurse or pharmacist for advice before taking any additional medicine.

INTERACTIONS WITH THIS MEDICATION

Tell your doctor, nurse or a pharmacist if you are taking or have recently taken any other medicines, including prescription and non-prescription drugs, eye drops, vitamins, and herbal supplements.

The following may interact with ULTIBRO BREEZHALER:

- Medicines used in the treatment of depression or sad mood (e.g. tricyclic antidepressants, monoamine oxidase inhibitors);
- Other medications (including combinations) that contain a long-acting beta agonist (LABA), such as formoterol, salmeterol, indacaterol, vilanterol, olodaterol;
- Other medications that contain a short-acting, or a long-acting muscarinic antagonist (LAMA) (e.g. ipratropium, tiotropium, glycopyrronium, aclidinium, umeclidinium).
- Ask your doctor or pharmacist if any of your other medicines are LABA or ipratropium or LAMA containing medicines;
- Medicines that decrease the level of potassium in your blood. These include diuretics (also known as “water tablets” and used to treat high blood pressure, e.g. hydrochlorothiazide), other bronchodilators such as methylxanthines used for breathing problems (e.g. theophylline) or steroids (e.g. prednisolone);
- Beta-blockers used in the treatment of high blood pressure or other heart problems (e.g. propranolol) or in the treatment of glaucoma (e.g. timolol);
- Ketoconazole (used to treat fungal infections);
- Ritonavir (Anti-HIV medicine);
- Erythromycin (used to treat bacterial infections);
- Verapamil (used to treat high blood pressure, severe chest pain, irregular heartbeat).

PROPER USE OF THIS MEDICATION

Always use this medicine exactly as your doctor, nurse or pharmacist has told you. Check with your doctor, nurse or pharmacist if you are not sure. Do not exceed the recommended dose prescribed by your doctor.

You can inhale ULTIBRO BREEZHALER before or after food or drink.

Usual adult dose:

Inhale the contents of one capsule through the mouth each day, every day at the same time. Inhaling ULTIBRO BREEZHALER at the same time each day will help to minimize your symptoms throughout the day and night and will also help you to remember to use it.

You only need to inhale once a day to help you breathe easier because the effects of ULTIBRO BREEZHALER last for 24 hours.

Use ULTIBRO BREEZHALER even when you have no breathing problems or other symptoms of COPD.

How long to use ULTIBRO BREEZHALER

Keep using ULTIBRO BREEZHALER for as long as your doctor tells you.

COPD is a long-term disease and you should use ULTIBRO BREEZHALER every day and not only when you have breathing problems or other symptoms of COPD.

If you have questions about how long to continue your treatment with ULTIBRO BREEZHALER, talk to your doctor or your pharmacist.

Each ULTIBRO BREEZHALER pack contains

- One or more ULTIBRO BREEZHALER inhalers consisting of a cap and a base
- One or more blisters containing ULTIBRO BREEZHALER capsules to be used in the inhaler



Only use the ULTIBRO BREEZHALER inhaler contained in this pack to inhale the powder in a capsule.

Do not use ULTIBRO BREEZHALER capsules with any other inhaler. Do not use ULTIBRO BREEZHALER inhaler to take any other capsule medicine.

Capsules should always be stored in the blister strip and only removed immediately before use.

When you start a new pack, use the new ULTIBRO BREEZHALER inhaler supplied in this new pack. Dispose of each inhaler after 30 days of use. Ask your pharmacist how to dispose of medicines and inhalers no longer required.

Do not swallow ULTIBRO BREEZHALER capsules. The powder in the capsules is for you to inhale.

How to use your ULTIBRO BREEZHALER inhaler:

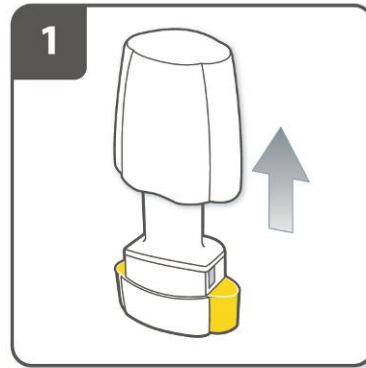

Pull off cap.



Open inhaler:

Hold the base of the inhaler firmly and tilt the mouthpiece to open the inhaler.

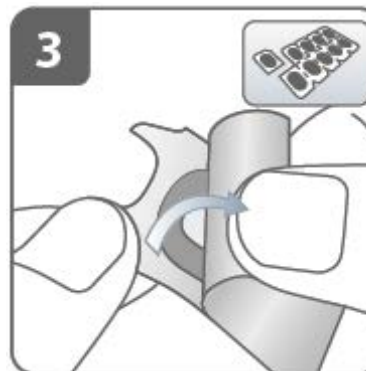

Prepare capsule:

Separate one of the blisters from the blister card by tearing along the perforation.

Take one blister and peel away the protective backing to expose the capsule.

Do not push capsule through foil.

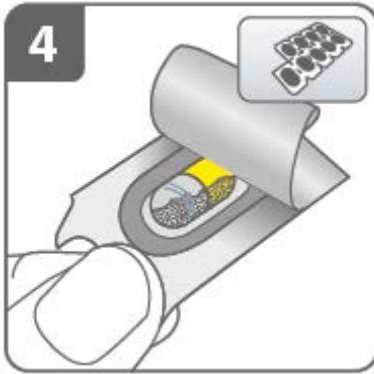

Remove one ULTIBRO BREEZHALER capsule:

Capsules should always be stored in the blister and only removed immediately before use.

With dry hands, remove capsule from the blister.

Do not swallow the ULTIBRO BREEZHALER capsule.

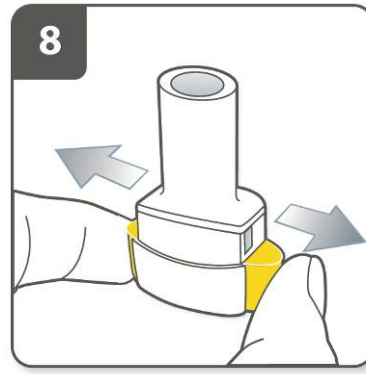

Release the buttons fully.

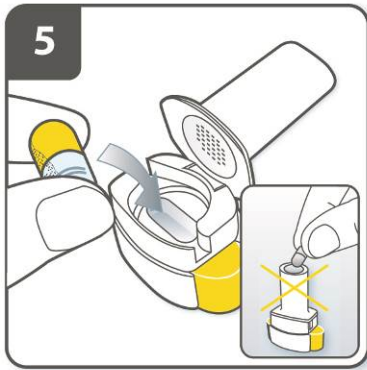

Insert capsule:

Place the capsule into the capsule chamber.

Never place a capsule directly into the mouthpiece.

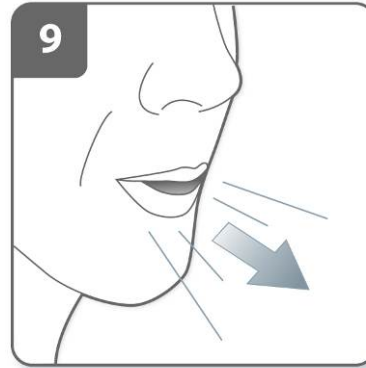

Breathe out:

Before placing the mouthpiece in your mouth, breathe out fully.

Never blow into the mouthpiece.



Close the inhaler:

Close the inhaler fully. You should hear a 'click' as it fully closes.

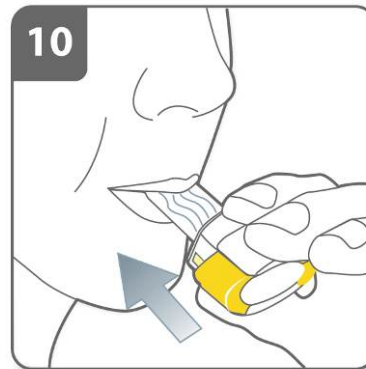

Inhale the medicine:

Before breathing in:

- Hold the inhaler as shown in the picture with the buttons to the left and right (not up and down).
- Place the mouthpiece in your mouth and close your lips firmly around the mouthpiece.
- Breathe in rapidly but steadily, as deeply as you can. **Do not press the piercing buttons.**

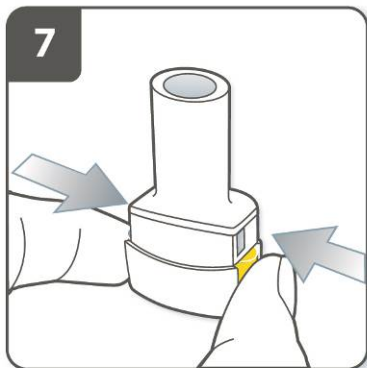

Pierce the capsule:

Hold the inhaler upright with the mouthpiece pointing up.

Press both buttons together firmly at the same time. You should hear a 'click' as the capsule is being pierced.



Note:

As you breathe in through the inhaler, the capsule spins around in the chamber and you should hear a whirring noise. You will experience a sweet taste as the medicine goes into your lungs.

Do not press the piercing buttons more than once.

If you do not hear a whirring noise, the capsule may be stuck in the capsule chamber. If this occurs, open the inhaler and carefully loosen the capsule by tapping the base of the inhaler. **Do not press**

the piercing buttons to loosen the capsule. Repeat steps 9 and 10 if necessary.

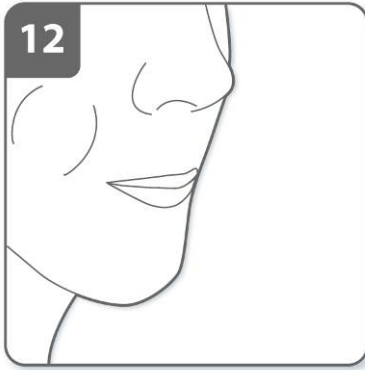

Hold breath:

Continue to hold your breath for at least 5-10 seconds or as long as comfortably possible while removing the inhaler from your mouth. Then breathe out.

Open the inhaler to see if any powder is left in the capsule. If there is powder left in the capsule, close the inhaler and repeat steps 9 to 12. Most people are able to empty the capsule with one or two inhalations.

Some people occasionally cough briefly soon after inhaling the medicine. If you do, don't worry, as long as the capsule is empty, you have received the full dose.

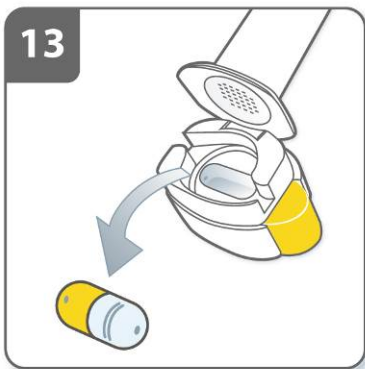

Remove capsule:

After you have finished taking your daily dose of ULTIBRO BREEZHALER, open the mouthpiece again, remove the empty capsule by tipping it out of the capsule chamber, and discard it. Close the inhaler and replace the cap.

Do not store the capsules in the ULTIBRO BREEZHALER inhaler.

REMEMBER:

- **Do not swallow ULTIBRO BREEZHALER capsules.**
- **Only use the ULTIBRO BREEZHALER inhaler contained in this pack.**
- ULTIBRO BREEZHALER capsules must always be stored in the blister, and only removed immediately before use.
- Never place a ULTIBRO BREEZHALER capsule directly into the mouthpiece of the ULTIBRO BREEZHALER inhaler.
- Do not press the piercing buttons more than once.
- Never blow into the mouthpiece of the ULTIBRO BREEZHALER inhaler.
- Always release the push buttons before inhalation.

- Never wash the ULTIBRO BREEZHALER inhaler with water. Keep it dry. See below "How to clean your inhaler".
- Never take the ULTIBRO BREEZHALER inhaler apart.
- Always keep the ULTIBRO BREEZHALER inhaler and ULTIBRO BREEZHALER capsules in a dry place.
- Avoid getting the drug powder in your eyes.

Additional information

Occasionally, very small pieces of the capsule can get past the screen and enter your mouth. If this happens, you may be able to feel these pieces on your tongue. It is not harmful if these pieces are swallowed or inhaled. The chances of the capsule shattering will be increased if the capsule is pierced more than once (step 7).

How to clean your inhaler

Never wash your inhaler with water. If you want to clean your inhaler wipe the mouthpiece inside and outside with a clean, dry, lint-free cloth to remove any powder residue. Keep the inhaler dry.

Overdose:

If you think you have inhaled too much ULTIBRO BREEZHALER, contact your doctor, nurse, pharmacist, hospital emergency department or regional Poison Control Centre immediately, even if there are no symptoms.

If you accidentally take a larger dose of ULTIBRO BREEZHALER you may feel shaky, have a headache, or feel like your heart is beating faster than usual. Talk to your doctor or pharmacist right away if this occurs.

Missed Dose:

If you forget to inhale a dose, inhale a dose as soon as possible on the same day. However, do not inhale two doses on the same day. Then inhale the next dose as usual.

SIDE EFFECTS AND WHAT TO DO ABOUT THEM

As with all medicines, patients using ULTIBRO BREEZHALER may experience side effects, although not everybody gets them.

Side effects may include:

- Feeling of pressure or pain in the cheeks and forehead (possible symptoms of sinusitis)
- Runny or stuffy nose, sneezing
- Dizziness
- Headache
- Cough
- Sore throat/or mouth
- Upset stomach, indigestion
- Cavities
- Pain in muscles, bones or joints
- Pain in extremities (e.g. arms or legs)
- Fever

- Chest pain
- Problem falling asleep
- Tingling or numbness
- Nose bleeds
- Dry mouth
- Skin itching/rash
- Muscle spasm
- Tiredness
- Nausea, vomiting, diarrhea and abdominal pain (possible symptoms of gastroenteritis)
- Combination of sore throat, runny nose (signs of nasopharyngitis)
- Fast heart beat
- Irregular heart beat (palpitations)
- Swollen hands, ankles and feet
- Muscle pain, aches or tenderness
- Blocked nose, sneezing, coughing, headache with or without fever (signs of upper respiratory tract infection)
- Disorders of the voice - hoarse, weak, breathy or strained voice, with or without pain or discomfort in the throat

If any of these affects you severely, **tell your doctor, nurse or pharmacist.**

ULTIBRO BREEZHALER can cause abnormal blood test results such as decreased levels of potassium and increased blood sugar. Your doctor will decide when to perform blood tests and will interpret the results.

If you notice any other side effects not mentioned in this leaflet, please inform your doctor, nurse or pharmacist.

SERIOUS SIDE EFFECTS, HOW OFTEN THEY HAPPEN AND WHAT TO DO ABOUT THEM				
Symptom / effect		Talk with your doctor, nurse or pharmacist		Stop taking drug and seek immediate medical help
		Only if severe	In all cases	
Paradoxical Bronchospasm: Sudden worsening of shortness of breath and wheezing right after inhaling ULTIBRO BREEZHALER				✓
Glaucoma: New or worsened pressure in your eyes, eye pain or discomfort, temporary blurred vision, seeing halos of bright colours around lights, red eyes				✓
Common	Serious Allergic Reaction: difficulties in breathing or swallowing, swelling of tongue, lips and face, skin rash, itching, and hives			✓
	Increased blood sugar: Increased thirst, frequent urination, increased appetite with weight loss, tiredness		✓	
	Urinary retention: Difficulty and pain when passing urine, needing to go often, urination in a weak stream or drips		✓	
	Bladder Infection: painful and frequent urination		✓	

SERIOUS SIDE EFFECTS, HOW OFTEN THEY HAPPEN AND WHAT TO DO ABOUT THEM				
Symptom / effect		Talk with your doctor, nurse or pharmacist		Stop taking drug and seek immediate medical help
		Only if severe	In all cases	
Uncommon	Crushing chest pain with increased sweating (signs of insufficient blood and oxygen supply of the heart). This may be a serious heart problem.			✓
	Irregular heartbeat	✓		

SERIOUS SIDE EFFECTS, HOW OFTEN THEY HAPPEN AND WHAT TO DO ABOUT THEM

Symptom / effect		Talk with your doctor, nurse or pharmacist		Stop taking drug and seek immediate medical help
		Only if severe	In all cases	
Not known	Decreased levels of potassium in the blood: Irregular heartbeats, muscle weakness and spasms and generally feeling unwell		✓	
	Angioedema: Swelling mainly of the tongue, lips, face and throat		✓	

This is not a complete list of side effects. For any unexpected effects while taking ULTIBRO BREEZHALER, contact your doctor, nurse or pharmacist immediately.

HOW TO STORE IT

Do not use after the expiry date shown on the box.

Store ULTIBRO BREEZHALER at room temperature between 15 to 25°C.

Store the capsules in the original package, in a dry place in order to protect from heat and moisture. Do not remove capsules from blister pack until immediately before use.

Keep this medicine out of the reach and sight of children

Each inhaler should be disposed of after 30 days of use.

Do not use this medicine if you notice that the pack is damaged or show signs of tampering. Ask your pharmacist how to dispose of medicines you no longer use.

REPORTING SIDE EFFECTS

You can report any suspected side effects associated with the use of health products to Health Canada by:

- Visiting the Web page on Adverse Reaction Reporting (<https://www.canada.ca/en/health-canada/services/drugs-health-products/medeffect-canada/adverse-reaction-reporting.html>) for information on how to report online, by mail or by fax; or
- Calling toll-free at 1-866-234-2345.

NOTE: Contact your health professional if you need information about how to manage your side effects. The Canada Vigilance Program does not provide medical advice.

MORE INFORMATION

This document plus the product monograph, prepared for health professionals can be found at: www.novartis.ca

or by contacting the sponsor, Novartis Pharmaceuticals Canada Inc., at: 1-800-363-8883

This leaflet was prepared by:
Novartis Pharmaceuticals Canada Inc.
385, Bouchard Blvd., Dorval, Quebec
H9S 1A9

Last revised: January 12, 2018

ULTIBRO is a registered trademark
BREEZHALER is a registered trademark